

Operator's Manual

Solara Trailer and Rail Heating Units



SOLARA

62-11807
Rev D





Operator's Manual
Solara
Trailer and Rail Heating Units

TABLE OF CONTENTS

1. INTRODUCTION.....	1
2. UNIT IDENTIFICATION	2
3. SAFETY	3
4. DISPLAY	4
5. STARTING UNIT.....	6
6. INSPECT MODE.....	7
7. INTELLISET	9
8. OPERATOR MESSAGES	11
9. CHANGING SETPOINT	13
10. START/STOP OPERATION.....	15
11. DATA RECORDER	16
12. LANGUAGE SELECTION	19
13. UNIT DATA	20
14. ALARM LIST	22
15. VIEW HOUR METERS.....	23
16. STOPPING UNIT	24
17. EMERGENCY BYPASS MODE	25
18. PRODUCT LOADING	26
19. GENERAL TROUBLESHOOTING	27
20. POWER CONTROL MODULE/MAIN MICRO MODULE.....	28
21. UNIT MAINTENANCE.....	30
22. WARRANTY.....	32
23. EMERGENCY ROAD SERVICE	33

1 Introduction

This guide has been prepared for the operator of a Carrier Transicold Solara™ heating unit with the APX™ Control System. This guide contains basic instructions for the daily operation of the unit as well as safety information, troubleshooting tips, and other information that will help you to deliver the load in the best possible condition. Please take the time to read the information contained in this booklet and refer to it whenever you have a question about the operation of this Carrier Transicold unit.

This heating unit has been engineered to provide long, trouble-free performance when it is properly operated and maintained. The checks outlined in this guide will help to minimize over-the-road problems. In addition, a comprehensive maintenance program will help to insure that the unit continues to operate reliably. Such a maintenance program will also help to control operating costs, increase the unit's working life, and improve performance.

This guide is intended as an introduction to this unit and to provide general assistance when needed. More comprehensive information can be found in the Operation and Service manual for this unit. This manual can be obtained from your Carrier Transicold dealer.

When having this unit serviced, be sure to specify genuine Carrier Transicold replacement parts for the highest quality and best reliability.

At Carrier Transicold, we are continually working to improve the products that we build for our customers. As a result, specifications may change without notice.

2 Unit Identification

Each unit is identified by a decal attached to the frame of the unit inside the door. This decal is on the lower frame cross member. The decal identifies the model name and model number of the unit, the warranty ID number, and the serial number.

If a concern arises, please refer to the information on this decal, and make a note of the model and serial number before calling for assistance. This information will be needed when you contact an authorized Carrier Transicold Dealer so that they may properly assist you.

3 Safety



WARNING

Unit may start automatically at any time even if the switch is in the OFF position. Use proper lockout/tagout procedures before inspection/servicing. All unit inspection/servicing by properly trained personnel only.

This Carrier Transicold heating unit has been designed with the safety of the operator in mind. During normal operation, all moving parts are fully enclosed to help prevent injury. During all pre-trip inspections, daily inspections, and problem troubleshooting, you may be exposed to moving parts. Please stay clear of all moving parts when the unit is in operation.

NOTE TO TECHNICIANS

Refer to the Operation and Service manual for a complete list of safety precautions.

3.1 Automatic Start

Your heating unit is equipped with auto-start. The unit may start at any time. A buzzer will sound for five seconds before the unit is started. When performing any check of the unit (e.g., visually checking the belt, checking the oil), place unit in Inspect mode and disconnect the starter solenoid connector.

3.2 Cooling System

The engine is equipped with a pressurized cooling system which includes a non-pressurized coolant overflow bottle. Under normal operating conditions, the coolant in the engine and radiator is under high pressure and is very hot. Contact with hot coolant can cause severe burns. Do not remove the cap from a hot coolant system. If the cap must be removed, cover it with a rag and remove very slowly in order to release the pressure without spray.

3.3 Battery

This unit may be equipped with a lead-acid type battery. The battery normally vents small amounts of flammable hydrogen gas. Do not smoke when checking the battery. A battery explosion can cause serious physical harm and/or blindness.

4 Display

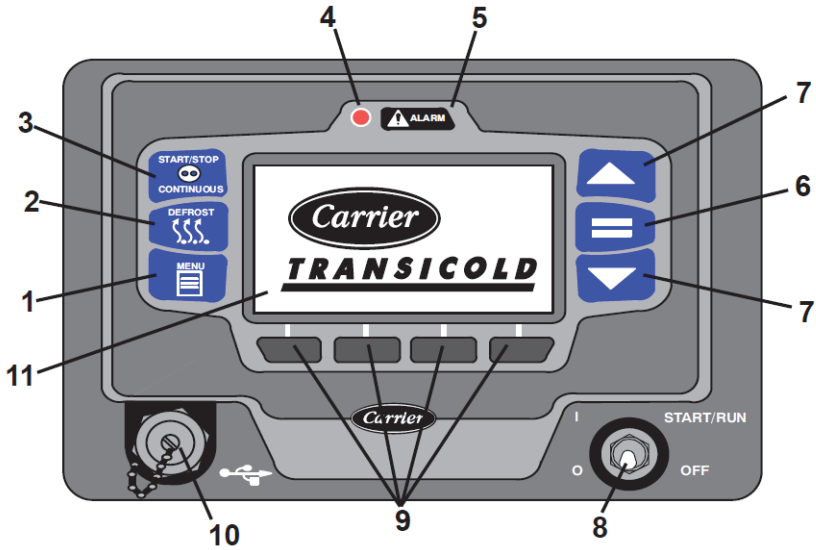

1. MENU key
2. DEFROST key (Not Applicable to this model)
3. START/STOP - CONTINUOUS Key (Not Applicable to this model)
4. Alarm LED
5. Alarm Key
6. “=” (Select) Key
7. Arrow Keys, ▲ and ▼
8. START/RUN-OFF Switch
9. Soft Keys
10. USB Interface Port
11. Display

4.1 Display Screens

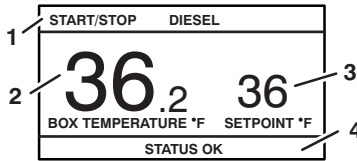

Default Screen

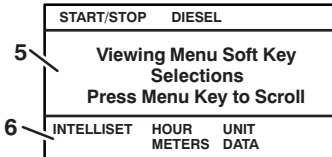

Typical Menu Screen

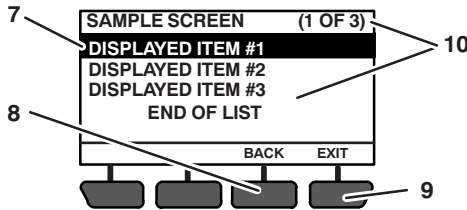

1. Status Bar
2. Box Temperature
3. Setpoint
4. Message Center
5. Operator Message Panel
6. Soft Key Descriptions
7. Highlight - White letters on black background
8. BACK key - Used to return to previous screen
9. EXIT key - Used to return to the default screen
10. The position of the highlighted item and total number of items in the list is displayed in the status bar. Up to five items may be displayed at one time. Press the ▼ key to view additional items, or the ▲ key to scroll back up the list. "END OF LIST" will be displayed after the last item in the list.

5 Starting the Unit



Under no circumstances should ether or any other starting aids be used to start the engine.

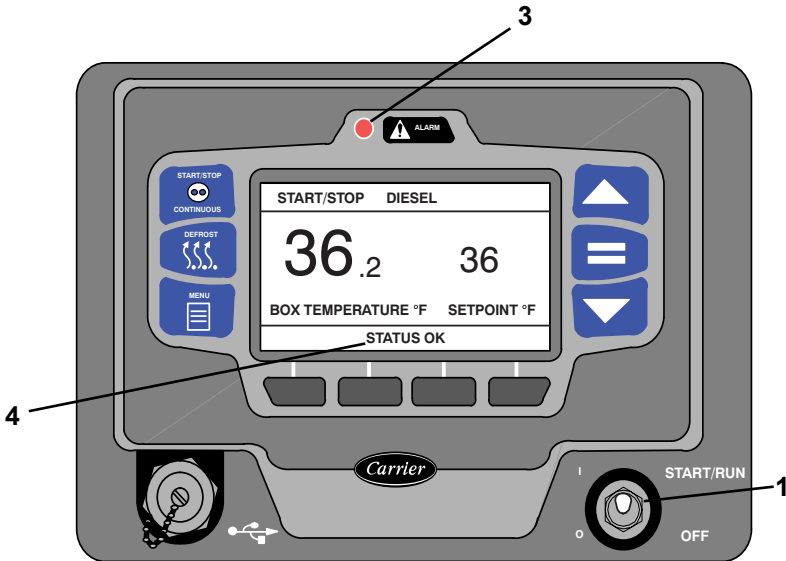

1. Place the START/RUN-OFF switch in the START/RUN position.
2. The system will display the Carrier Transicold logo and the default screen, present language selection and hour meter readings (if configured to do so) along with a test flash of the alarm light and light bar amber LEDs. The system will then perform a start sequence, energize the buzzer for five seconds, and start the unit automatically.
3. If there is an alarm present, the alarm message will be displayed in the MessageCenter and the alarm LED will flash for five seconds. If one or more shutdown alarms are present, the alarm(s) must be cleared before the unit will start.
4. Once the unit is operating, observe the MessageCenter. If the word “ACTIVE” or “MODIFIED” is displayed at the right, the unit is equipped with IntelliSet™ settings, refer to [Section 7](#)

6 Inspect Mode

- Inspect mode provides an additional layer of safety for operators and technicians. Inspect mode should be used during all pretrip inspections of the unit.
- Inspect mode is a user activated feature that forces the unit to shut-down and remain in shutdown regardless of operating state.
- After unit inspection, Inspect mode must be manually disabled, at which point the unit will resume standard operation.
- Inspect mode is not a substitute for proper Lockout/Tagout procedures, which are always required when servicing the unit.

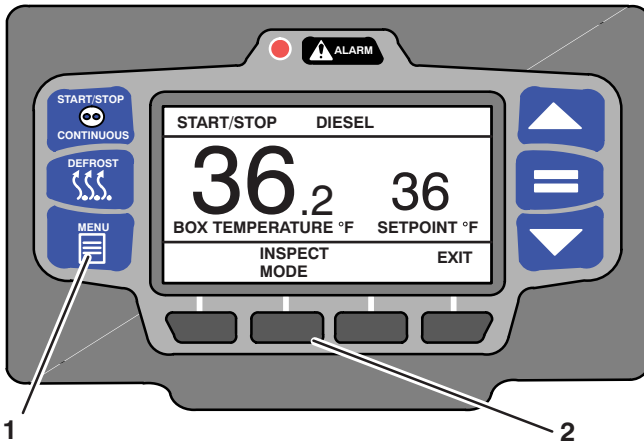

6.1 Enter Inspect Mode

1. With the system powered up (START/RUN-OFF switch in the START/RUN position), press the MENU key until INSPECT MODE is displayed.
2. Press the INSPECT MODE soft key. The unit will shut down.

While the unit is in Inspect mode, the ALARM light will flash, and the display will indicate that unit operation, including temperature control, has been disabled.

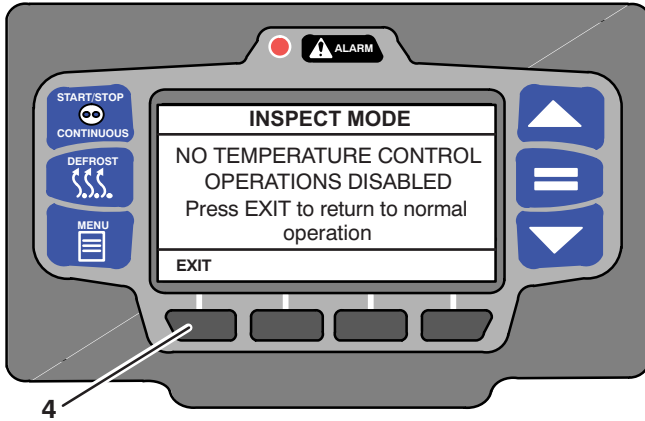

6.2 Exit Inspect Mode

3. While the unit is in Inspect mode, the EXIT soft key will be available, all other keys and functions will be locked out.
4. Press the EXIT soft key to disable Inspect mode, the unit will resume standard operation.

7 IntelliSet™

Products carried or stored in a compartment require a multitude of unit settings that must be checked and, if required, reset each time a new product is loaded. The APX Control system offers the settings necessary to meet these requirements. IntelliSet is a feature that allows pre-selection and naming of the necessary settings for over 40 different products. The operator may then call up the settings by simply selecting the assigned IntelliSet name.

NOTE

Factory IntelliSets are available from your authorized Carrier Transicold Truck/Trailer dealer.

IntelliSet may be pre-programmed as “IntelliSleep” which allows Sleep mode to be entered by simply changing to that IntelliSet.

7.1 Select an IntelliSet

1. With the system powered up (START/RUN-OFF switch in the START/RUN position) or in PC mode and the default screen displayed, press the “=” key.

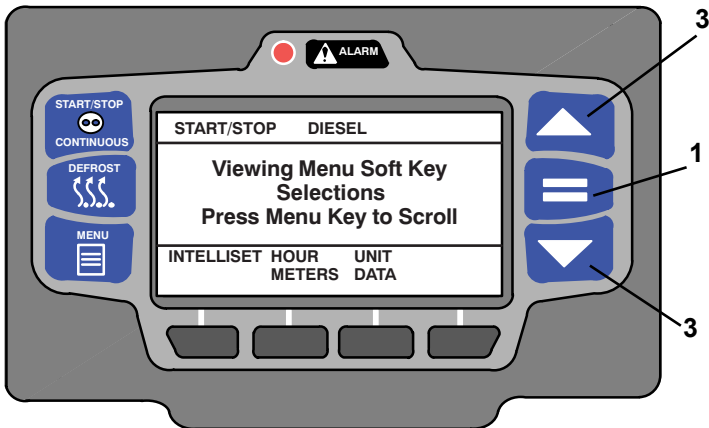

2. Verify that the IntelliSet screen is displayed. If not, press the MENU key until INTELLISET is displayed. Then, press the INTELLISET soft key to display the IntelliSet screen.

3. The IntelliSet screen will display with a 10 second timeout and five of the available IntelliSets listed. The IntelliSet that is currently selected will have the word “Active” or “Modified” to the right. There may be more than five IntelliSets available, as displayed in parenthesis on the first line.
4. Press the ▲ or ▼ key to scroll through the list of available IntelliSets. To change to another IntelliSet, highlight the IntelliSet desired and press the “=” key. The highlighted IntelliSet will become active and an “INTELLISET CHANGED” message will display.
5. Press the EXIT soft key to return to the default display.

8 Operator Messages

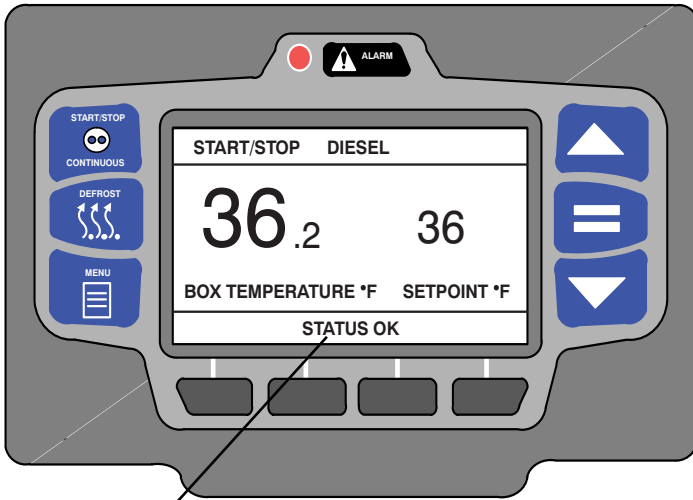

“STATUS OK” - This message or other user-defined message will be displayed in the MessageCenter at most times.

If a problem develops or the operation has been changed, one of the following messages may be displayed:

- **CHECK AT NEXT SERVICE INTERVAL:** Displayed when there is an active non-shutdown alarm present (the alarm condition is present but is not serious enough to shut down the unit). These alarms may be viewed by pressing the ALARM key. The message will clear itself when the condition is corrected.
- **DOOR OPEN:** Displayed if an optional door switch is installed and configured to notify you when the door is opened or not closed tightly.
- **LOSS OF COMMUNICATIONS:** Displayed when there is a problem between one or more modules and the display module.
- **CHECK FUEL LEVEL:** Displayed if an optional fuel level sensor is installed in the tank, the level is low and fuel needs to be added.
- **SLEEP MODE, OFF / ON TO WAKE:** Displayed when the unit is in Sleep mode, and the engine has cycled off.

- **SLEEP WARNING NO TEMP CONTROL:** Displayed when the unit is running while in Sleep mode.
- **TECHNICIAN RESET REQUIRED:** Displayed if the Low Engine Oil Pressure or High Coolant Temperature alarm has been activated three times in the last two hours and the unit has been locked out. The unit must be brought to a Carrier Transcold Dealer for service.
- **BATTERY VOLTAGE TOO LOW:** Displayed when the unit battery voltage is too low to allow the unit to start and run.
- **UNIT SHUTDOWN - DOOR OPEN or REMOTE SWITCH:** Displayed if an optional door or remote switch is installed and configured to shut the unit down when the compartment door is opened or remote switch is activated.
- **UNIT SHUTDOWN:** Displayed when there is a safety shutdown. Pressing the ALARM key will bring any Active Alarms into the MessageCenter.

9 Changing Setpoint

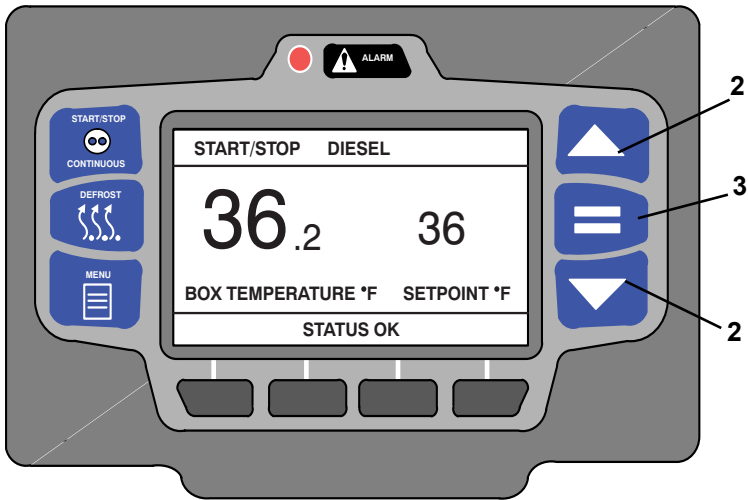

1. Verify that the system is powered up (START/RUN-OFF switch in the START/RUN position) or in PC mode and the default screen displayed (press the Back soft key if required):
2. Press the ▲ or ▼ key to bring the displayed setpoint to the desired value.

TIP

The setpoint will change one degree with each press and release of an arrow key or the setpoint will scroll if the arrow key is pressed and held.

3. Press the “=” key to save the new setpoint. The MessageCenter will display “SETPOINT CHANGED” for 10 seconds.
4. If the “=” key is not pressed the setpoint screen will flash, the MessageCenter will display “SETPOINT NOT CHANGED” and then return to original setpoint.

By default, setpoints of 0°F to +95°F (-17.8°C to +35°C) may be entered using the display mounted keys. The APX Control System always retains the last entered setpoint in memory. The setpoint will change 1° (one full degree) OR 0.1° (one tenth of a degree - if configured to do so) for each press and release of the ▲ or ▼ key.

NOTE

The APX Control System may be configured with a minimum and / or maximum setpoint other than the default values listed above. "MAX SETPOINT HAS BEEN REACHED" or "MIN SETPOINT HAS BEEN REACHED" will display in the MessageCenter when either of these conditions is reached.

Setpoint may be changed any time the START/RUN - OFF switch is in the START/RUN position, or when the unit is in PC mode EXCEPT when:

- Viewing the Alarm List, Data List or Functional Parameters **OR**
- When the unit is in Sleep mode.

Pressing the = key will cause the new displayed setpoint value to become active and "SETPOINT CHANGED" will be displayed. If the new value is not entered, after 10 seconds of no display mounted key activity, the entire display and Light Bar will flash (with "SETPOINT NOT CHANGED" displayed) and then revert back to the last entered setpoint. All other keys are active at this time and if a key is pressed while the display is flashing, the flashing will stop, and the requested function will be performed.

TIP

The setpoint may be changed quickly by pressing and holding the ▲ or ▼ key until the desired setpoint is reached. The longer the key is held, the faster the setting will change.

10 Start-Stop Operation

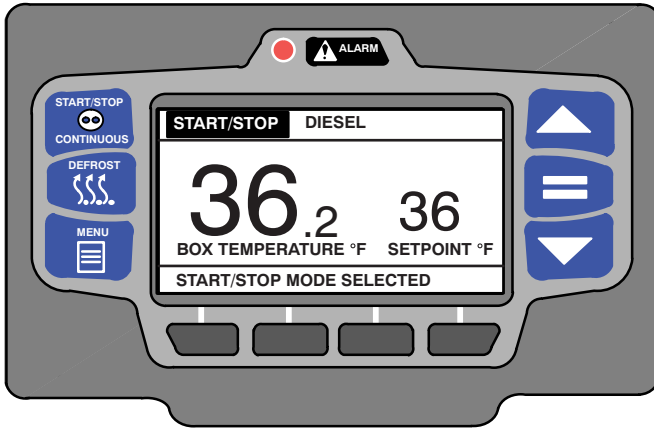

The unit is configured to run only in Start/Stop Operation. Start-Stop reduces fuel consumption by allowing fully automatic control of unit shut down and restart by monitoring the compartment temperature, battery charge condition and engine coolant temperature.

The main function of Start-Stop Operation is to turn off the unit near setpoint to provide an efficient temperature control system and to initiate a restart sequence after certain conditions are met. The APX Control System may be configured with Start-Stop operation tied to setpoint ranges.

The Start-Stop/Continuous key is locked out. “Not Available for Selected Model” displays when this key is pressed.

If the unit fails to start after three start attempts the **00031 FAILED TO START - AUTO MODE** alarm will be activated. While running, if the unit shuts down, an internal counter keeps track of the shutdowns. Should the unit shutdown three consecutive times without running a minimum of 15 minutes between shutdowns the **00030 FAILED TO RUN MINIMUM TIME** alarm will be activated. The shutdown counter is cleared when the unit has run for 15 minutes.

11 Data Recorder

The APX Control System contains a built-in DataLink™ data recorder. The recorded data can be downloaded from the DataLink data recorder using either the TRU-Tech/TRU-View program or a Carrier Transicold APX USB Flash Drive.

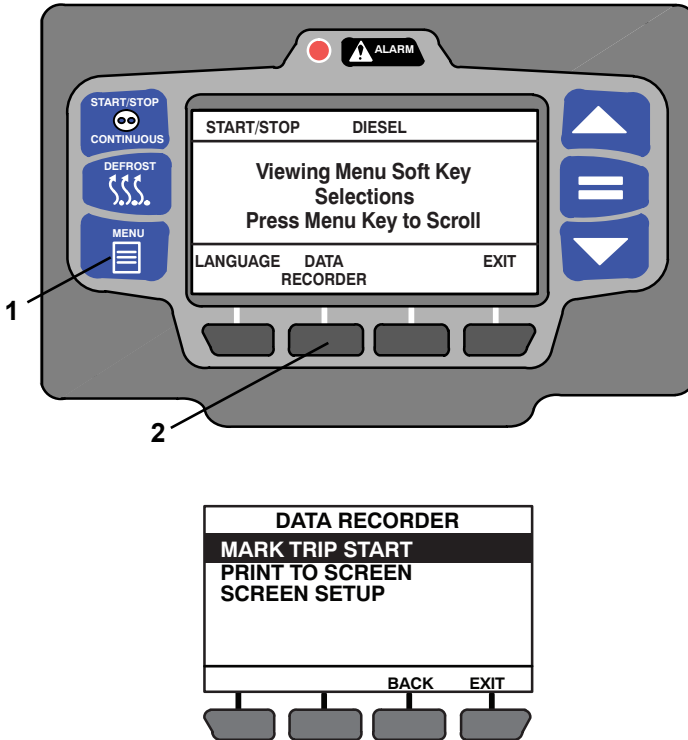

1. With the system powered up (START/RUN-OFF switch in the START/RUN position) press the MENU key until DATA RECORDER is displayed.
2. Press the DATA RECORDER soft key to display the sub menus.

- The Data Recorder screen will display with a 15-second timeout. Press the ▲ or ▼ key to scroll through the available sub menus. With the desired sub menu highlighted, press the “=” key to enter the menu.

NOTE

Choices vary based on software revision and model type.

11.1 Mark Trip Start

Trip Start places the present time and date as a stamp in the data recorder memory to allow easy review of the data from the last trip, and to allow downloading data from a specific trip. A trip begins at a Trip Start and ends at the next Trip Start. To enter a Trip Start, with MARK TRIP START highlighted, press the “=” key. If trip start is acknowledged by the data recorder, “TRIP START ENTERED” will be displayed for five seconds and then the display will revert back to the normal display. In the unlikely situation that the data recorder is not functioning properly “CANNOT ENTER TRIP START” will flash and the display will revert back to the Data Recorder menu.

11.2 Print to Screen

PRINT TO SCREEN displays a graphical representation of the recorded data. To display the data: with PRINT TO SCREEN highlighted, press the “=” key.

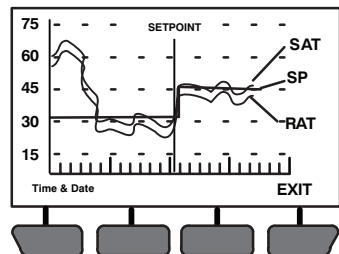
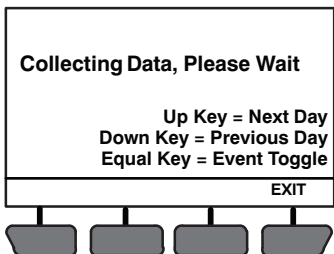

NOTE

If configured to do so, the system will prompt for entry of the data protect PIN code before any data recorder print functions can be used. If this code is not entered, all print functions are locked out.

Once the graphical display is presented, press the ▲ or ▼ key to move through the recorded data, day by day. The data is presented with the left horizontal axis as 00:00 (midnight) with 24 dividing lines representing the hours of the day.

Press the “=” key to toggle the event codes on or off. When viewing events with the event codes ON, the following acronyms will be displayed:

- | | |
|----------------|----------------------------|
| c = Door Close | r = Real time clock change |
| o = Door open | f = Power down |
| p = Power up | t = Trip Start |

12 Language Selection

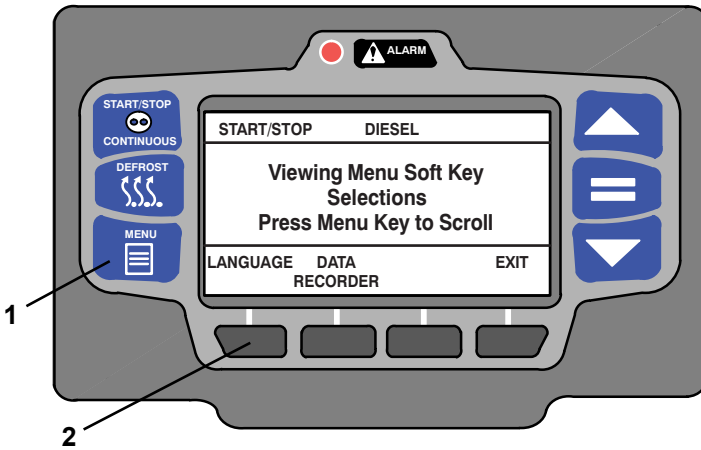

1. With the system powered up (START/RUN-OFF switch in the START/RUN position) or in PC mode press the MENU key until LANGUAGE is displayed.
2. Press the LANGUAGE soft key to display the language screen. The language screen will display with a 10-second timeout.

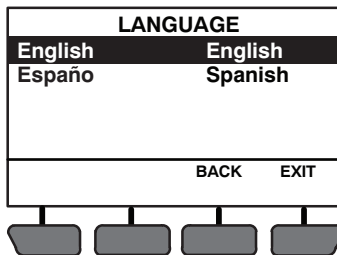

3. Press the ▲ or ▼ key to scroll through the available selections.
4. With the desired language highlighted, press the “=” key. The highlighted language will become active and “LANGUAGE CHANGED” will be displayed.

13 Unit Data

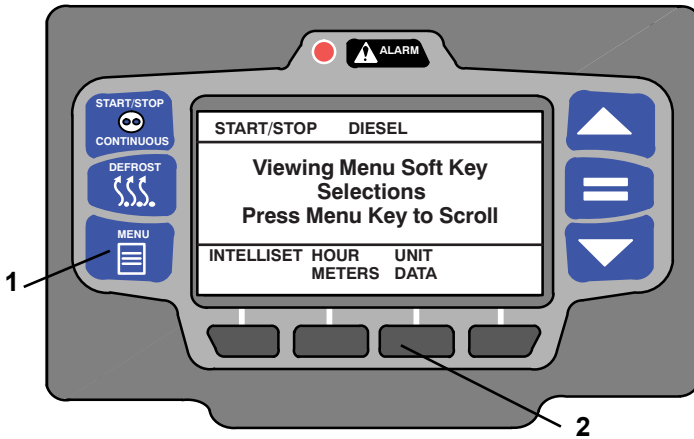

1. With the system powered up (START/RUN-OFF switch in the START/RUN position) or in PC mode, press the MENU key until UNIT DATA is displayed.
2. Press the UNIT DATA soft key to display the unit data screen.
3. The Unit Data screen will display with a 15-second timeout. Press the ▲ or ▼ key to scroll through the available unit data sub menus. With the desired sub menu highlighted, press the “=” Key to view the data.
4. The selected sub menu data will be displayed.
5. Press the ▲ or ▼ key to scroll through the sub menu data list.
6. To lock the present display view, press the LOCK SCREEN soft key. The screen will highlight (white lettering on a black background) to indicate it is locked and the soft key will change to UNLOCK SCREEN.
7. Press the UNLOCK SCREEN soft key to unlock the screen or press the ▲ or ▼ key to unlock the screen and scroll through the sub menu data selections. Press the BACK key to return to the sub menu selection screen or the EXIT key to return to the default screen.

Table 1–1 Unit Data

DATA	DEFINITION
ENGINE	
FUEL LEVEL	This is only displayed when the optional sensor is installed and configured YES. Displays percentage of fuel in tank.
BATTERY	Battery voltage
AMP DRAW	Battery charging or discharging amps
ENGINE COOLANT TEMP	Engine coolant temperature
TEMPERATURE SENSORS	
AMBIENT AIR TEMP	Ambient air temperature
RETURN AIR TEMP	Return air temperature
SUPPLY AIR TEMP	Supply air temperature
DELTA-T	Supply air temperature minus Return air temperature
SYSTEM INFORMATION	
DATE	This is the current date and time that the system is using. This may be different than your actual time, depending on the time zone and daylight- saving time selections made by the owner of the unit.
TIME	The system uses a 24-hour clock. Hours 00 to 11 are AM and hours 12 to 23 are PM.
TRAILER ID #	Trailer ID (as entered by the user)
UNIT SERIAL #	Unit serial number
UNIT MODEL #	Unit model number (entered in Configuration)
MICRO SOFTWARE REVISION	Revision of the software that is operating the main microprocessor module
DISPLAY SOFTWARE REVISION	Revision of the software that is operating the display module
MAIN MICRO SERIAL #	Serial Number of the main microprocessor module
INSTALLED OPTIONS (Will display if one or more options installed)	
INTELLISET	If displayed, the IntelliSet option is installed.

14 Alarm List

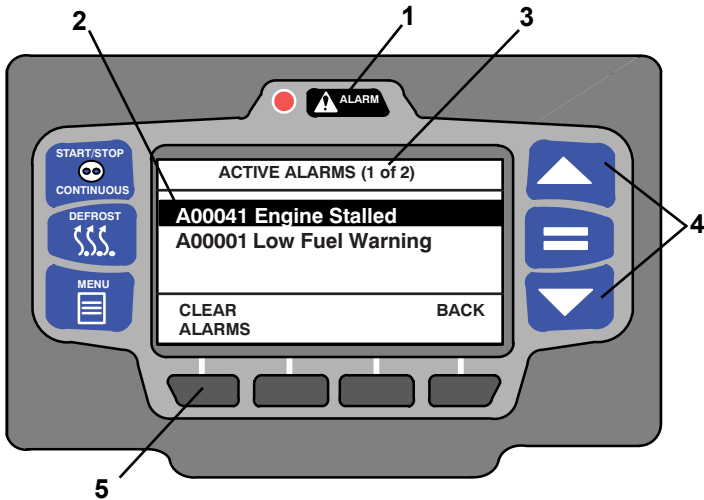

1. With the system powered up (START/RUN-OFF switch in the START/RUN position) press the ALARM key.
2. If there are active alarms, the alarm number will be displayed preceded by the letter "A" (active alarm). The last alarm that occurred will be the first alarm displayed.
3. Next to the ACTIVE ALARMS screen name in the status bar, information on the total number of alarms and the position in the list of the highlighted alarm is provided. (In the preceding illustration there are two alarms and the first alarm is highlighted.)
4. Press the ▲ or ▼ key to scroll through the list of alarms.
5. To clear the alarms, press the CLEAR ALARMS soft key. The display will provide an "ACTIVE ALARMS CLEARED" message to confirm the alarms have cleared.
6. If there are no active alarms, the display will provide a "NO ACTIVE ALARMS" message and then return to the default display after five seconds.

15 View Hour Meters

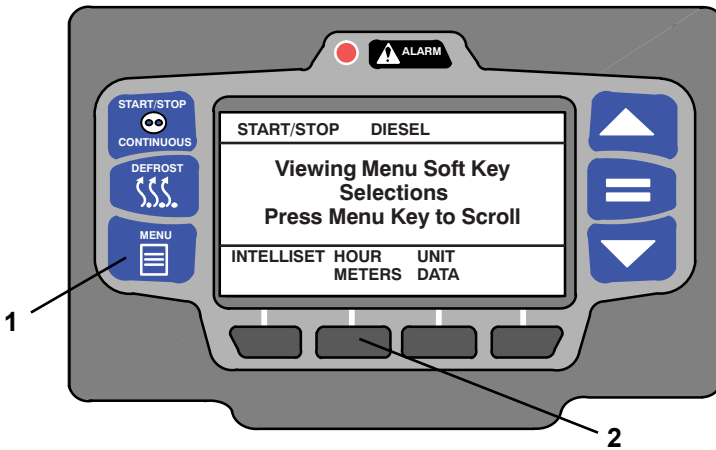

1. With the system powered up (START/RUN-OFF switch in the START/RUN position) or in PC mode, press the MENU key until HOUR METERS is displayed.
2. Press the HOUR METERS soft key to display the hour meters screen.

STANDARD HOUR METERS (3 of 3)	
Engine Hours	1050 Hours
Switch On Hours	1400 Hours
Total Run Hours	1050 Hours
END OF LIST	
BACK	EXIT

Below the table, there are four physical buttons. The first two buttons correspond to the 'BACK' and 'EXIT' soft keys shown in the table above.

3. The hour meters screen will display with a 15-second timeout. Press the EXIT soft key to return to the default screen.

16 Stopping The Unit

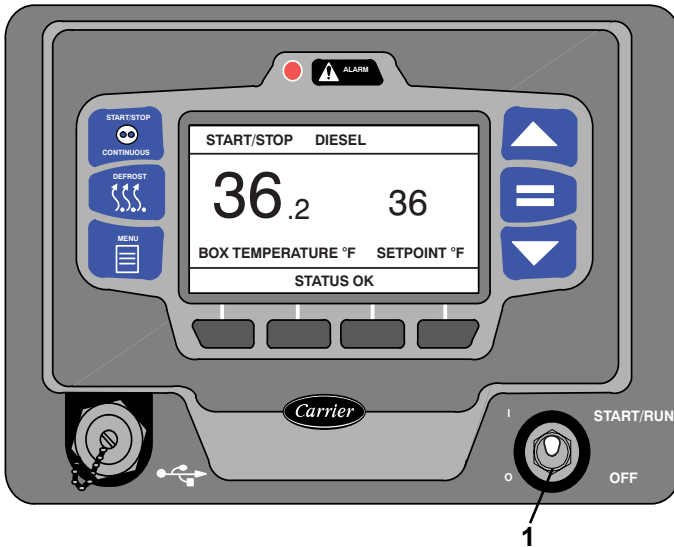

1. To stop the unit, place the START/RUN-OFF switch in the OFF position. The unit will shutdown immediately while the system completes a shutdown sequence and then the display will go blank.
2. The engine will stop and the display will turn off.

NOTE

Due to internal processing, power cycling the START/RUN - OFF switch will result in a 4 to 50-second delay between the display going off and coming back on again.

WARNING

Unit may start automatically at any time even if the switch is in the OFF position. Use proper lockout/tagout procedures before inspection/servicing. All unit inspection/servicing by properly trained personnel only.

17 Emergency Bypass Mode

In the event of an alarm caused by a failure of the display module, the unit will go into shutdown. In order to temporarily bypass this shutdown state, Emergency Bypass mode can be activated.

Once Emergency Bypass mode has been activated, the unit will operate normally for 24 hours, a countdown timer will be shown on the display. This 24-hour window of operation will keep the load safe, and provide enough time to contact the nearest Carrier Transicold Service Center for repair of the unit.

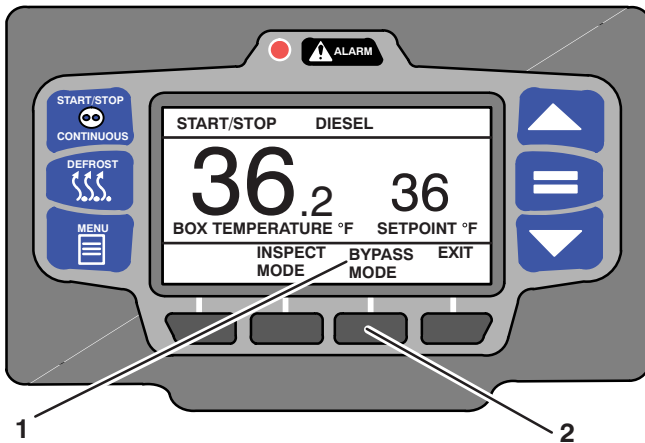

17.1 Enter Emergency Bypass Mode

1. When the unit is in a shutdown state due to the display module alarm, press the MENU key until BYPASS MODE is displayed.
2. Press the BYPASS MODE soft key, the unit will resume operation until Emergency Bypass mode is disabled, or after 24 hours of unit operation in Emergency Bypass mode.

17.2 Exit Emergency Bypass Mode

3. Press the MENU key until the EXIT BYPASS soft key is displayed.
4. Press the EXIT BYPASS soft key, the unit will shut down. Once Emergency Bypass mode is turned off, it cannot be restarted and the unit will remain in shutdown until it is repaired.

After repairs have been made and the display module alarm has been cleared, the unit will operate normally and Emergency Bypass mode will no longer be available.

18 Product Loading

18.1 Before Loading

Pre-heat the compartment. This will provide the product better protection when it is loaded.

18.2 During Loading

- Stop the unit (place the START/RUN-OFF switch in the OFF position)
- Check product temperature during loading
- Ensure that the air returns and supply openings remain unobstructed
- Leave approximately 4 to 5 inches (100 to 125 mm) between the load and compartment front wall for air return to the unit
- Leave at least 10 to 12 inches (250 to 300 mm) between the top of the load and the ceiling to ensure that there is nothing to prevent airflow
- Load product on pallets to provide free air return to unit and improve product protection

Proper air circulation in the compartment, air that can move around and through the load, is a critical element in maintaining product quality during transport.

The use of pallets is highly recommended. Pallets help protect product when loaded so air can flow freely through the pallets to return to the unit. When using pallets, it is important to refrain from stacking extra boxes on the floor at the rear of the compartment as this will cut off the airflow.

Product stacking is another important factor in protecting the product. All products should be kept away from the side-walls of the body, to allow air flow between the body and the load. It is important to check the temperature of the product being loaded to ensure that it is at the correct temperature for transport. The heating unit is designed to maintain the temperature of the product at the temperature at which it was loaded.

19 General Troubleshooting



WARNING

Unit may start automatically at any time even if the switch is in the OFF position. Use proper lockout/tagout procedures before inspection/servicing. All unit inspection/servicing by properly trained personnel only.

Everything possible has been done to ensure that this unit is the most reliable, trouble-free equipment available today. If you experience problems the following section may be of assistance.

If you do not find the trouble that you have experienced listed, please call your Carrier Transicold dealer for assistance.

Unit won't crank	Check alarm list Check battery condition Check battery connections Check all fuses
Unit won't start	Check alarm list Check fuel level Check all fuses
Unit stops operating	Check alarm list Check fuel level Check belt Check engine oil level Check coolant level Check all fuses
Unit not heating properly	Check alarm list Check for airflow restriction Check compartment for damage or air leaks

20 Power Control Module (PCM) / Main Micro Module (MM)

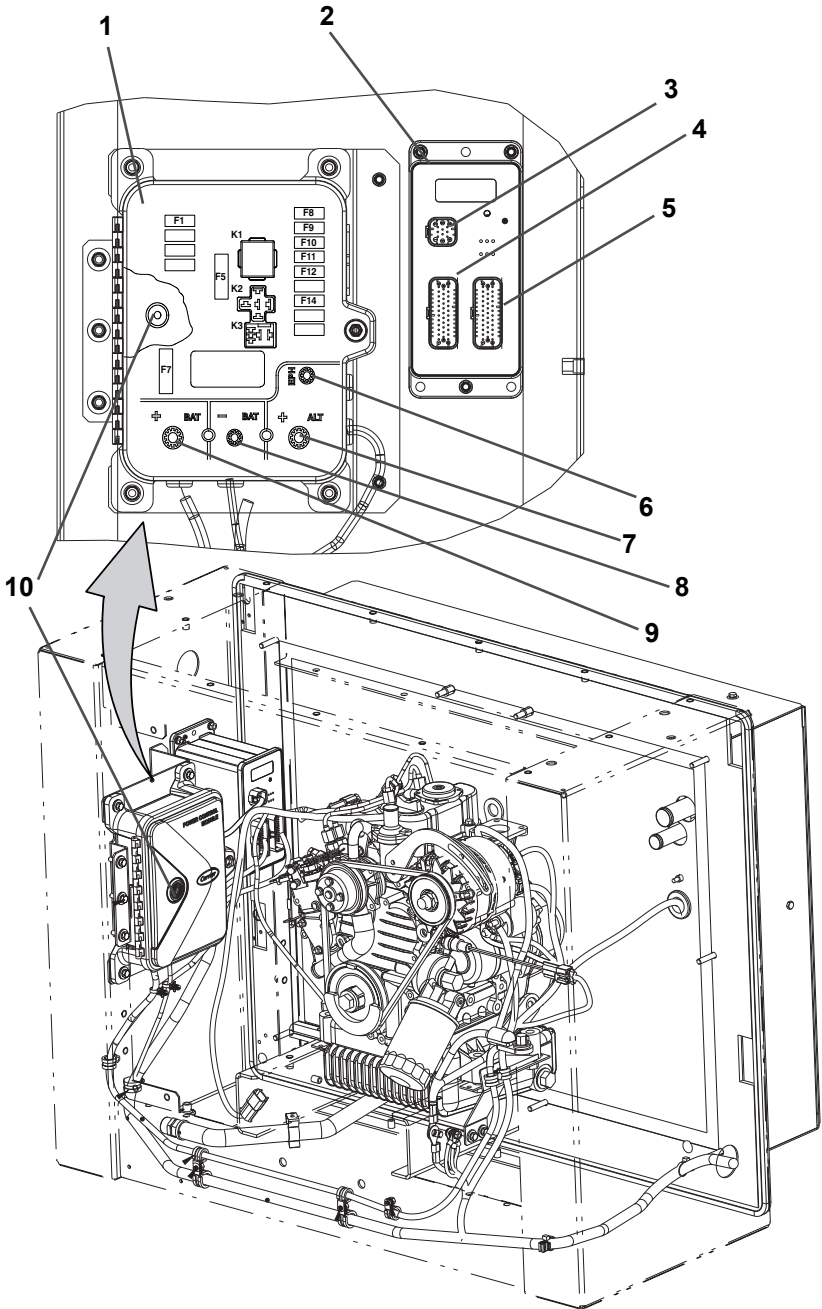

1. Power Control Module (PCM):

Fuses:

- a. Fuse (F1 = 5 amp), Module Logic Circuit and Buzzer Power
- b. Fuse (F5 = 30 amp), Power Enable Relay Contact Power
- c. Fuse (F7 = 80 amp) Main Power
- d. Fuse (F8 = 5 amp), Fuel Level Sensor Power (Option)
- e. Fuse (F9 = 10 amp), Fuel Pump
- f. Fuse (F10 = 20 amp), Main Microprocessor
- g. Fuse (F11 = 5 amp), Light Bar Power
- h. Fuse (F12 = 5 amp), Satellite Communications Power
- i. Fuse (F14 = 15 amp), Fuel Heater Power

Relays:

- a. K1 Relay, Power Enable (PER)
- b. K2 Relay, Fuel Heater (FHR)
- c. K3 Relay, Fuel Pump (FPR)

2. Main Micro Module (MM)

3. 1MM Connector

4. 2MM Connector

5. 3MM Connector

6. (Glow Plug) Engine Preheater Power Connection (T4)

7. Alternator Output Connection (T3)

8. Battery Negative Connection (T2)

9. Battery Positive Connection (T1)

10. Buzzer (B)

21 Unit Maintenance

For the most reliable operation and for maximum life, this unit requires regular maintenance. This includes oil and filter changes, fuel filter and air cleaner replacement and coolant replacement.

21.1 Maintenance Schedule

Maintenance procedures should be performed according to the following schedule:

SYSTEM	OPERATION
a. Every Service Interval¹ or Yearly	
Engine	<ol style="list-style-type: none"> 1. Change lube oil and filters¹ 2. Check low oil pressure switch 3. Clean crankcase breather 4. Check engine speed
Fuel System	<ol style="list-style-type: none"> 1. Clean pump strainer 2. Change fuel filter¹ 3. Check fuel heater operation
Cooling System	<ol style="list-style-type: none"> 1. Check antifreeze concentration¹ 2. Clean radiator fin surface 3. Check water pump 4. Check radiator cap pressure setting 5. Check water temperature sensor
Exhaust System	<ol style="list-style-type: none"> 1. Check mounting hardware 2. Check muffler and exhaust pipes
Air Intake System	Change air cleaner element
Starting Circuit	<ol style="list-style-type: none"> 1. Clean battery connections and cable ends 2. Check battery hold down clamps 3. Check battery condition 4. Check starter operation 5. Check cable routing for any chafing or rubbing
Charging Circuit	<ol style="list-style-type: none"> 1. Check alternator brushes and replace if necessary 2. Check alternator output
Unit	<ol style="list-style-type: none"> 1. Check unit mounting bolts 2. Check engine mounting bolts 3. Check door latches and hinges 4. Check electrical connections 5. Check belt condition and tension. Adjust or replace as necessary¹.
b. Every 1,500 Hours	
Check fuel injectors ²	
c. Every 3,000 Hours	
Check fuel injection pump ²	

21.3 Checking Engine Oil Level

1. Run the unit to bring the engine up to operating temperature.
2. Shut the unit off.
3. Remove the dipstick, wipe it off and re-insert it fully into the engine block.
4. Once again, remove the dipstick and observe the oil level. It should be somewhere between the full and add marks. If it is below the add mark, add oil until the level is correct.

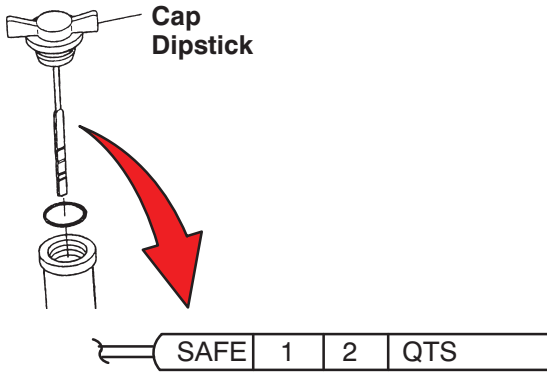

22 Warranty

Carrier Transicold offers warranty coverage to the initial and subsequent owners during the warranty coverage period. The warranty coverage terms are available on request through the Carrier Transicold dealer network. For Solara units, please request 62-12149 for the manufacturer's warranty document.

23 Emergency Road Service

At Carrier Transcold we're working hard to give you complete service when and where you need it. That means a worldwide network of dealers that offer 24-hour emergency service. These service centers are manned by factory trained service personnel and backed by extensive parts inventories that will assure you of prompt repair.

Should you experience a problem with your unit during transit, follow your company's emergency procedure or contact the nearest Carrier Transcold service center. Consult the Shortstop Service Centers directory or visit www.trucktrailer.carrier.com and click on "Dealer Locator" to locate the service center nearest you. The Shortstop directory may be obtained from your Carrier Transcold dealer.

You can also download the Carrier Transcold North America Truck/Trailer Dealer Locator App to your smart phone. The Dealer Locator App provides:

- Location information for every Carrier Transcold dealer in North America
- The nearest dealer from your present location
- Dealer look-up capability
- Dealer services (Trailer, Truck, APU, Mobile Support, etc.)
- Addresses
- Maps to easily find dealers
- Directions and navigation to the dealerships
- Phone number and 24-hour emergency hot lines, where available
- Auto dialing
- Hours of operation
- Link to dealer website
- Ability to add dealers to Contacts

To download the Carrier Transcold North America Truck/Trailer Dealer Locator App, scan this QR code, or go directly to your App store.



If you are unable to reach a service center, call our 24-hour Action Line: (800) 448-1661.

We will do everything we can to get your problem taken care of by an authorized CTD dealer and get you back on the road.

 **WARNING:** Breathing diesel engine exhaust exposes you to chemicals known to the State of California to cause cancer and birth defects or other reproductive harm.

- Always start and operate engine in a well-ventilated area.
- If in an enclosed area, vent the exhaust to the outside.
- Do not modify or tamper with the exhaust system.
- Do not idle the engine except as necessary.

For more information, go to www.P65warnings.ca.gov/diesel



North America
Carrier Transicold
700 Olympic Drive
Athens, GA 30601 USA

Central America and Mexico
Carrier Transicold
Ejercito Nacional 253-A Piso 5
Colonia Anahuac 11320 Mexico D.F.