



Carrier Transicold Division
Carrier Corporation
P.O. Box 4805
Syracuse, New York 13221

THIS DOCUMENT AND THE INFORMATION CONTAINED THEREIN IS PROPRIETARY TO CARRIER CORPORATION AND SHALL NOT BE USED OR DISCLOSED TO OTHERS, IN WHOLE OR IN PART, WITHOUT THE WRITTEN AUTHORIZATION OF CARRIER CORPORATION.

SUBMISSION OF THESE DRAWINGS OR DOCUMENTS DOES NOT CONSTITUTE PART PERFORMANCE OR ACCEPTANCE OF CONTRACT

CROSS REFERENCE INDEX		
DESCRIPTION	INSTALLATION DRAWING NO.	KIT NUMBER
REMOTE FUEL TANK - 22" DIAMETER	98-02201	---
INTEGRAL FUEL TANK	98-03336	76-02037-00
INTEGRAL FUEL PUMP INSTALLATION (INSTRUCTIONS ONLY)	98-03337	SUPPLIED WITH UNIT PACKAGING FOR UNITS ORDERED WITH INTEGRAL FUEL TANK OPTION

PART NO.	MODEL DESCRIPTION	KIT NUMBER (REFERENCE)
98-03335-01	NDH APX - UNIT USING REMOTE FUEL TANK	76-02036-00
98-03335-02	NDH APX - UNIT USING INTEGRAL FUEL TANK OPTION	76-02036-01

INSTALLATION PROCEDURE

- 1.0 THE TRAILER STRUCTURE MUST BE EVALUATED BY THE TRAILER MANUFACTURER TO DETERMINE ITS ABILITY TO WITHSTAND THE LOADS IMPOSED BY THE UNIT OVER ITS SERVICE LIFE. CARRIER TRANSICOLD DOES NOT CONVEY ANY ENDORSEMENT OR WARRANTY FOR THE TRAILER'S STRUCTURAL INTEGRITY. WEIGHTS:
SOLARA HEATING UNIT (WET, LESS BATTERY): 450 LBS [204 KGS]
REMOTE FUEL TANK: REFER TO INSTALLATION INSTRUCTIONS LISTED IN "CROSS REFERENCE INDEX" CHART
INTEGRAL TANK AND MOUNTING HARDWARE-W/O FUEL: 170 LBS [70 KGS]
W/ FUEL: 595 LBS [270 KGS]
- 2.0 UNIT MOUNTING SURFACES OF THE TRAILER THAT CONTACT THE UNIT MOUNTING PADS MUST BE UNI-PLANAR TO WITHIN 0.13(3) TO PREVENT DISTORTION OF THE UNIT AND/OR TRAILER.
- 3.0 TRAILER SURFACES THAT CONTACT THE UNIT MOUNTING GASKET SHOULD NOT PROTRUDE MORE THAN 0.19(5) ABOVE THE PLANE DEFINED BY THE MOUNTING PAD SURFACES TO ENSURE PROPER AIR SEAL.

FOR BEST RESULTS

- (A) DO NOT LOAD CARGO AGAINST THE INTERNAL BULKHEAD(S).
- (B) USE AIR RETURN BULKHEAD WITH VERTICAL RIBBING TO PROMOTE AIR CIRCULATION AROUND THE CARGO.
- (C) LOAD CARGO ON PALLETS OR CARTS, ESPECIALLY WHEN FLAT FLOORING IS USED.
- (D) FOR BEST AIR DISTRIBUTION AND PRODUCT PROTECTION, AN AIR CHUTE (DUCT) SHOULD BE USED.

CONTENTS	SHEET
GENERAL INFORMATION	1
SWING RADIUS	2
UNIT DIMENSIONAL DATA	
TRAILER PREPARATION	3
UNIT LIFTING REQUIREMENTS	4
UNIT INSTALLATION	
BATTERY INSTALLATION	5

SHEET INDEX	REV	C	B	B	B	C
	SHEET	1	2	3	4	5

SEE SEPARATE PARTS LIST

C	UPDATED SHEET INDEX, SEE SHT 5.	20 JUL 2015	LT-DG	JD		72N0295P15
B	UPDATED SHEET INDEX, SEE SHT 2 THRU SHT 5.	09 FEB 2015	LT-DG	JD		72N0223P15
A	INITIAL RELEASE OF -01 & -02.	28 MAR 14	LT-DG	JD		72N0230P14
SYM	REVISION RECORD	DATE	BY	ENGR.	M.E.	NPCA NO.

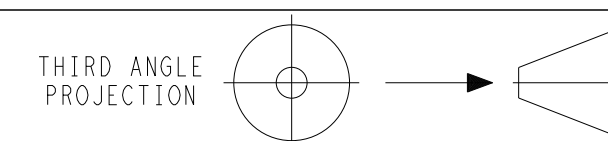

IMPERIAL INCH FORMAT:
UNLESS OTHERWISE SPECIFIED
DIMENSIONS ARE IN INCHES WITH
METRIC CONVERSIONS IN [MILLIMETERS]

TITLE

INSTL INSTR
SOLARA NDH APX

DRAWING NO.

98-03335

REV

C

SHEET 1 of 5



Carrier Transicold Division
Carrier Corporation
P.O. Box 4805
Syracuse, New York 13221

THIS DOCUMENT AND THE INFORMATION CONTAINED THEREIN IS PROPRIETARY TO CARRIER CORPORATION AND SHALL NOT BE USED OR DISCLOSED TO OTHERS, IN WHOLE OR IN PART, WITHOUT THE WRITTEN AUTHORIZATION OF CARRIER CORPORATION.

SUBMISSION OF THESE DRAWINGS OR DOCUMENTS DOES NOT CONSTITUTE PART PERFORMANCE OR ACCEPTANCE OF CONTRACT

UNIT DIMENSION INFORMATION

CONVERSION CHART	
DECIMAL INCHES	FRACTIONAL INCHES
1.34	1-5/16
2.66	2-11/16
3.70	3-11/16
6.85	6-7/8
7.86	7-55/64
13.38	13-3/8
17.07	17-1/16
19.03	19-0
25.20	25-3/16
25.59	25-5/8
27.62	27-5/8
28.60	28-5/8
44.52	44-1/2
52.34	52-5/16
52.55	52-9/16
55.18	55-3/16
59.94	59-15/16
65.30	65-5/16
66.30	66-5/16

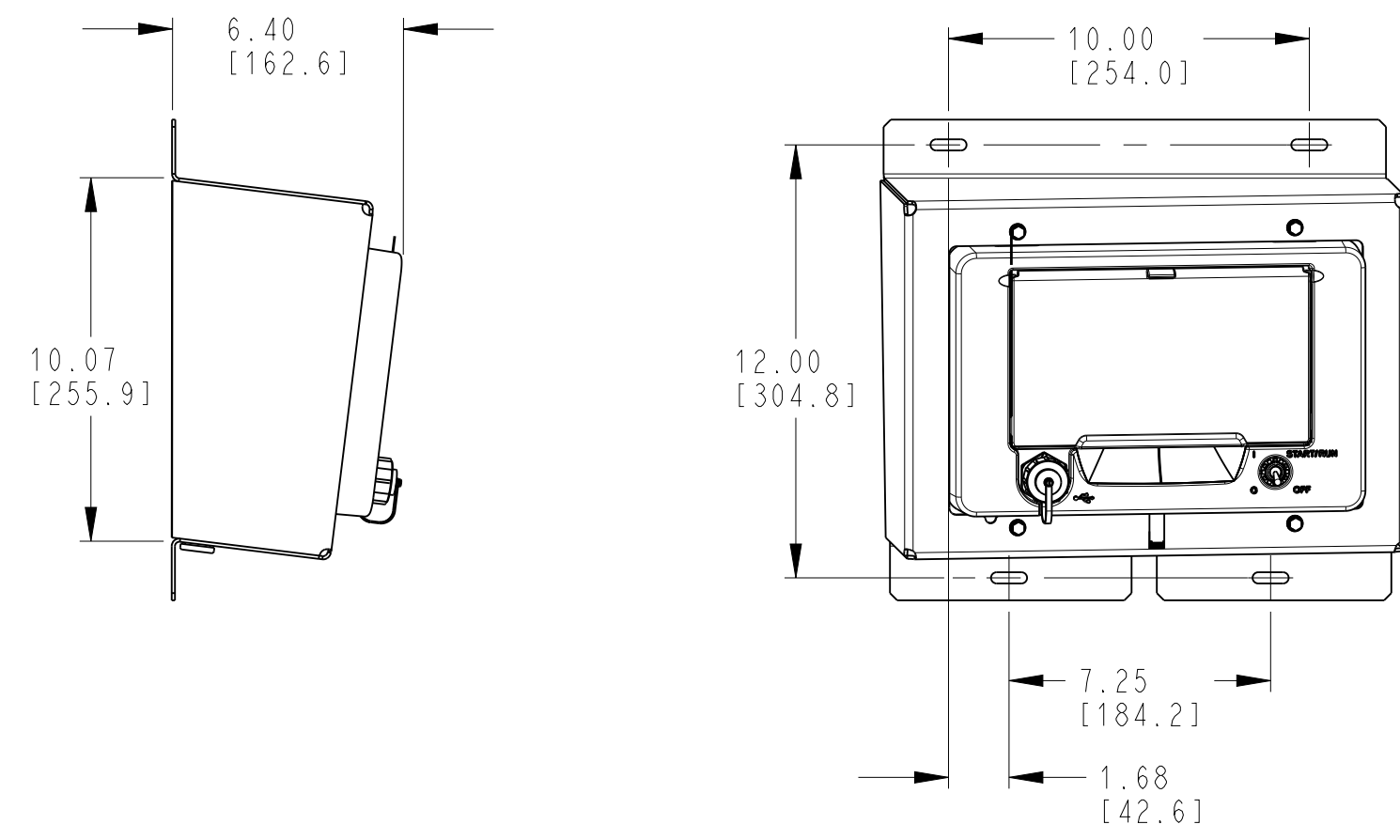

DISPLAY MODULE ASSEMBLY

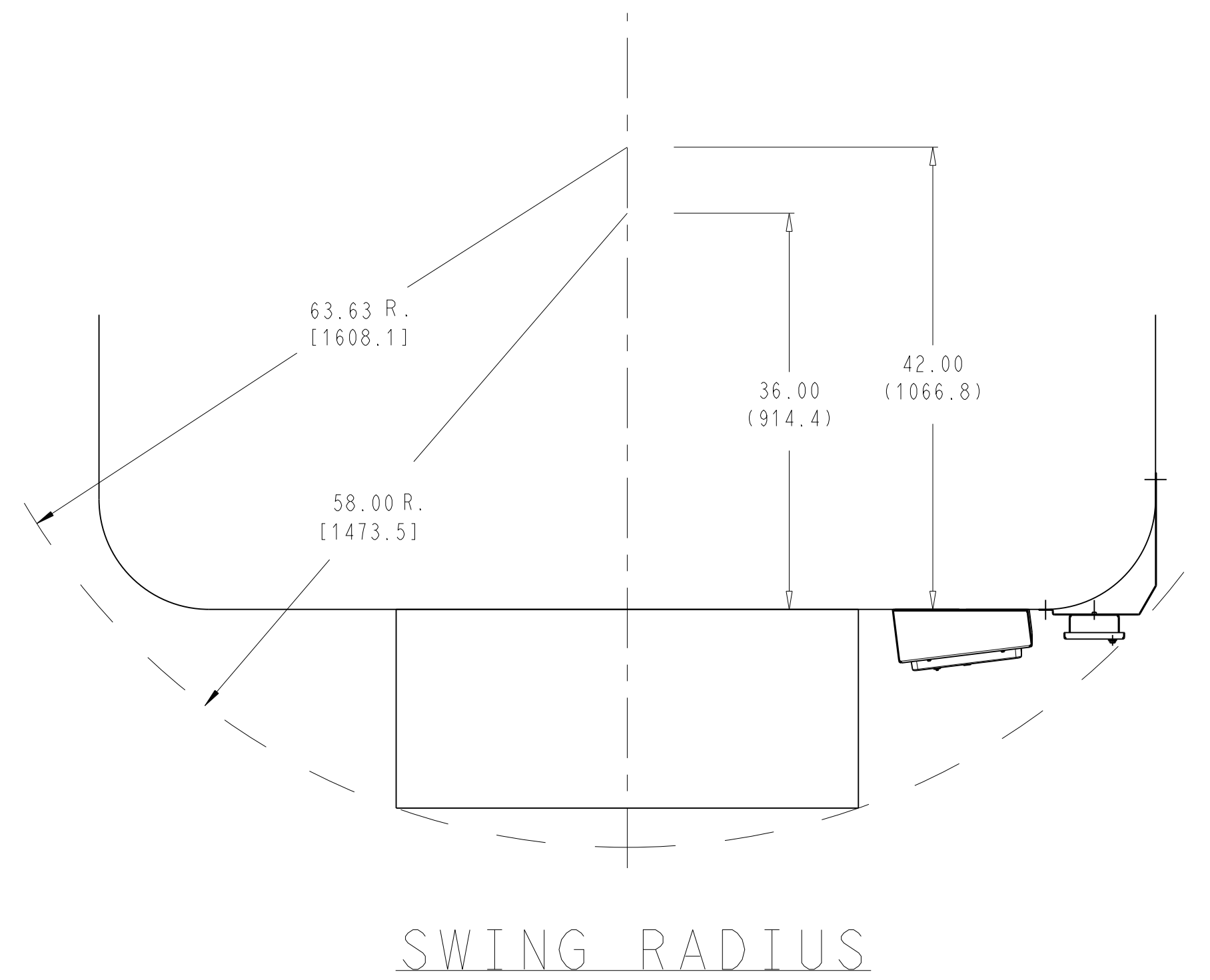

SWING RADIUS

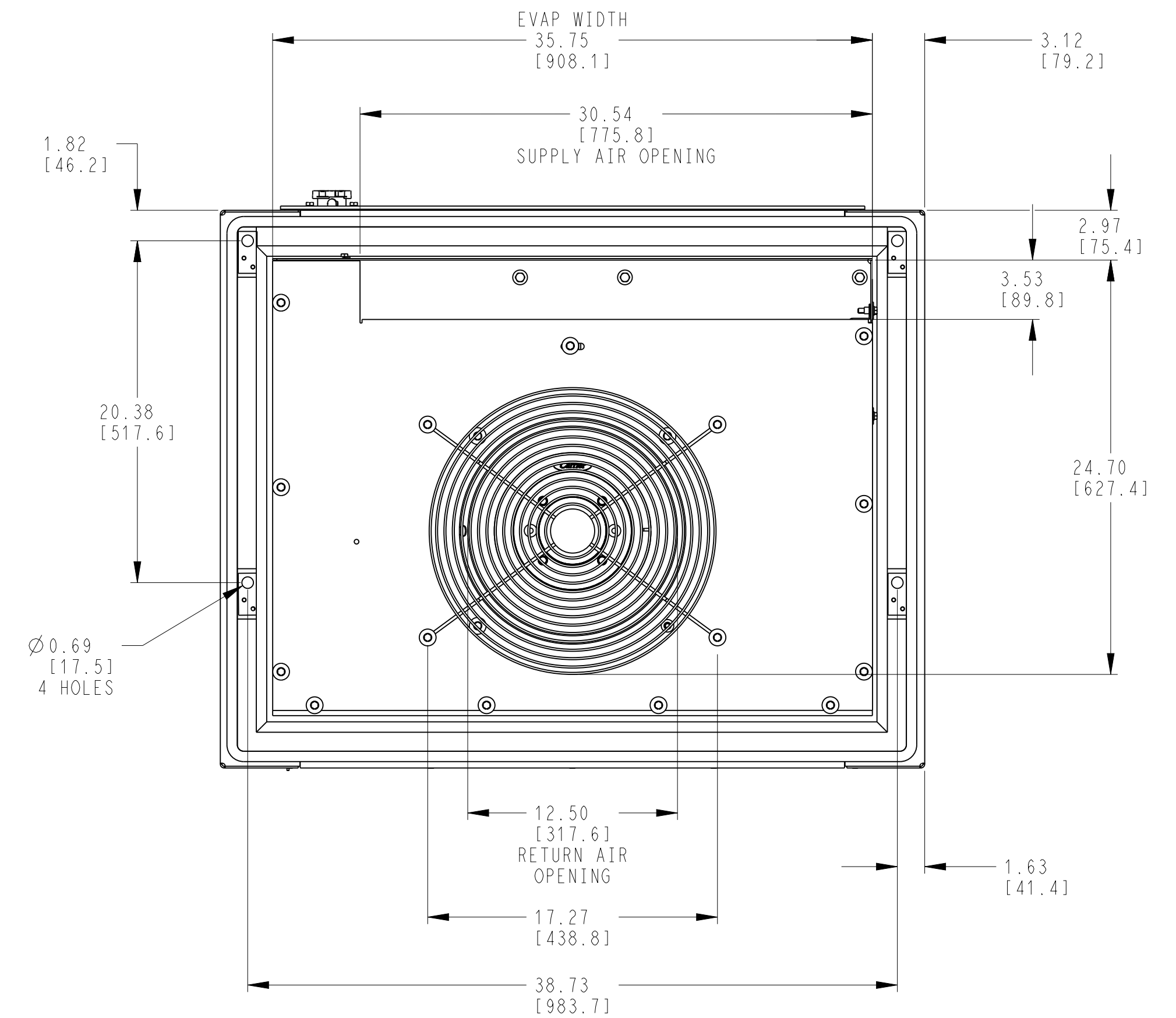
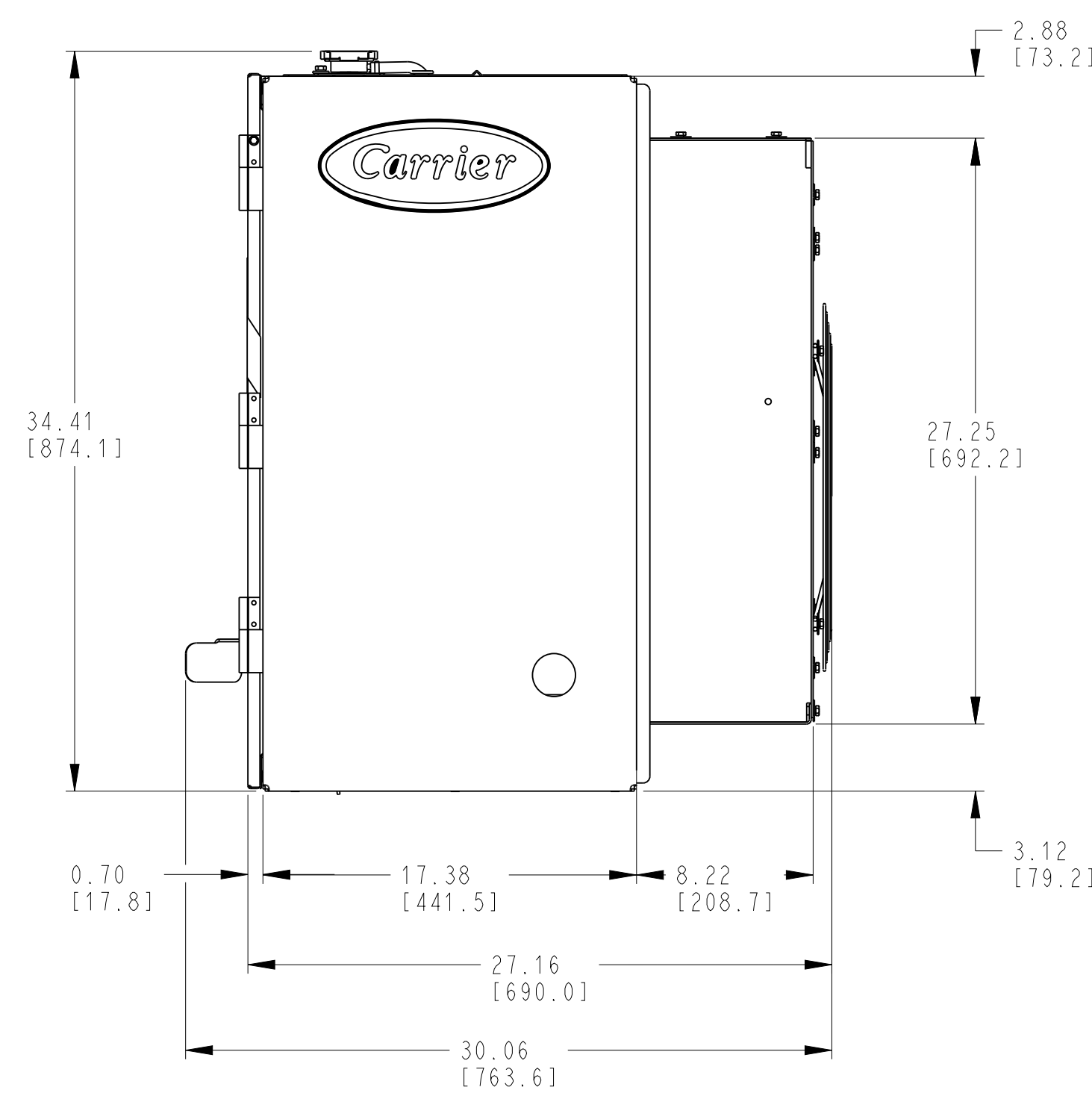
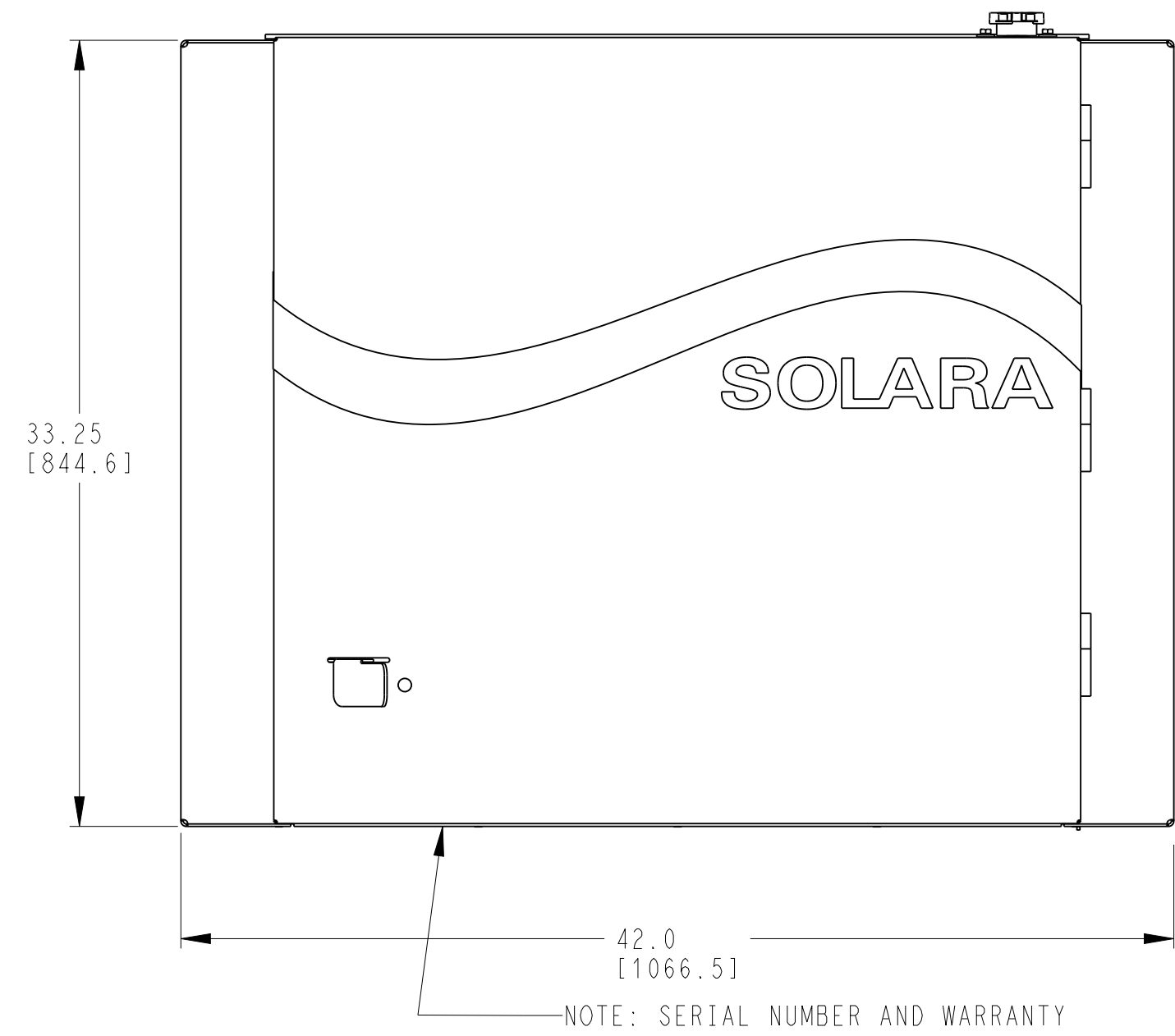

B	UPDATED OVERALL DIMENSIONS.	09 FEB 2015	LT-DG	JD		72N0223P15
A	INITIAL RELEASE OF -01 & -02.	28 MAR 14	LT-DG	JD		72N0230P14
SYM	REVISION RECORD	DATE	BY	ENGR.	M.E.	NPCA NO.

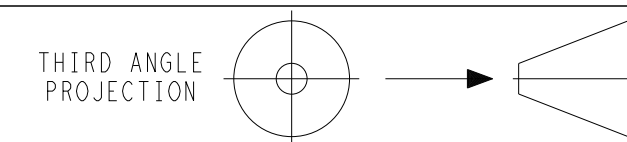

IMPERIAL INCH FORMAT:
UNLESS OTHERWISE SPECIFIED
DIMENSIONS ARE IN INCHES WITH
METRIC CONVERSIONS IN [MILLIMETERS]

TITLE

INSTL INSTR
SOLARA NDH APX

DRAWING NO.	REV
98-03335	B
SHEET 2 OF	

SUPERSEDES

PRINT DISTRIBUTION

EXPORT CLASSIFICATION:



Carrier Transicold Division
Carrier Corporation
P.O. Box 4805
Syracuse, New York 13221

THIS DOCUMENT AND THE INFORMATION CONTAINED THEREIN IS PROPRIETARY TO CARRIER CORPORATION AND SHALL NOT BE USED OR DISCLOSED TO OTHERS, IN WHOLE OR IN PART, WITHOUT THE WRITTEN AUTHORIZATION OF CARRIER CORPORATION.

SUBMISSION OF THESE DRAWINGS OR DOCUMENTS DOES NOT CONSTITUTE PART PERFORMANCE OR ACCEPTANCE OF CONTRACT

CONVERSION CHART	
DECIMAL INCHES	FRACTIONAL INCHES
1.50	1-1/2
1.91	1-29/32
5.66	5-21/32
8.25	8-1/4
18.50	18-1/2
19.38	19-3/8
20.38	20-3/8
27.88	27-7/8
38.75	38-3/4
47.38	47-3/8

CAUTION: UNIT MOUNTING SURFACES OF TRAILER THAT CONTACT THE UNIT MOUNTING PADS MUST BE UNI-PLANAR TO WITHIN 0.13[3] TO PREVENT DISTORTION OF UNIT AND/OR TRAILER.

CAUTION: TRAILER SURFACES THAT CONTACT THE UNIT MOUNTING GASKET SHOULD NOT PROTRUDE MORE THAN 0.19[5] ABOVE THE PLANE DEFINED BY THE MOUNTING PAD SURFACES TO ENSURE PROPER AIR SEAL.

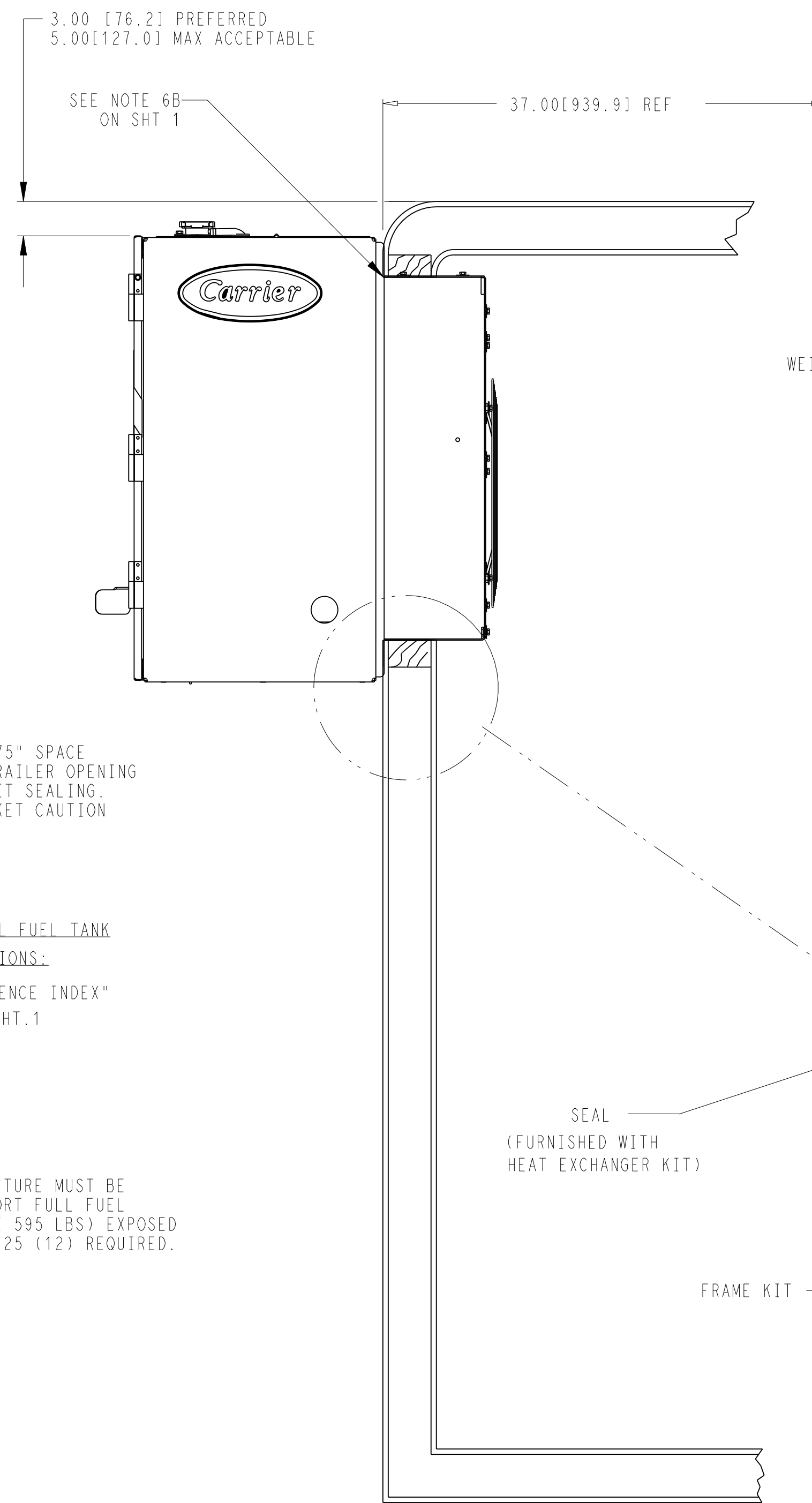
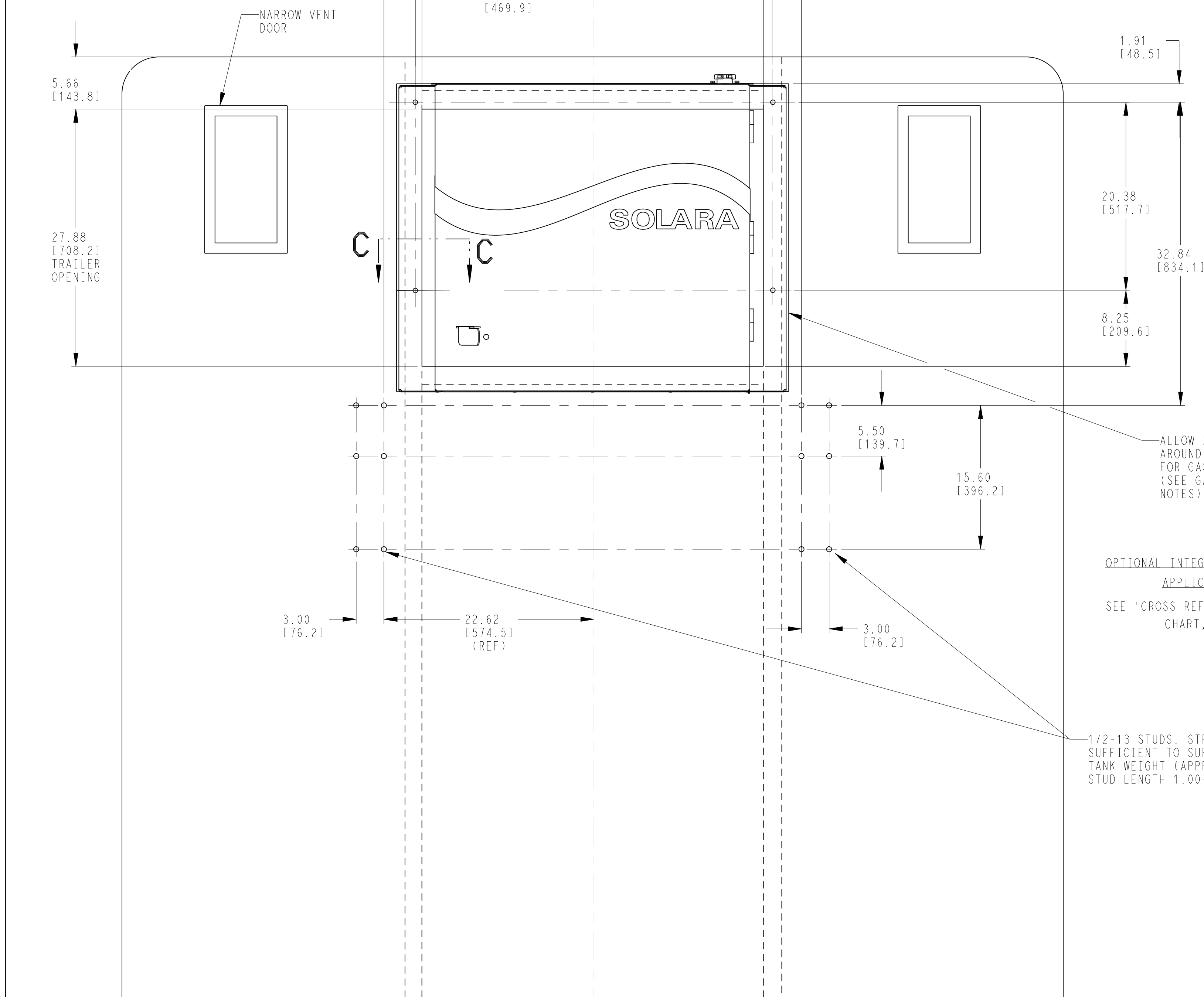

ALLOW 2.75" SPACE AROUND TRAILER OPENING FOR GASKET SEALING. (SEE GASKET CAUTION NOTES)

OPTIONAL INTEGRAL FUEL TANK APPLICATIONS:
SEE "CROSS REFERENCE INDEX" CHART, SHT.1

1/2-13 STUDS. STRUCTURE MUST BE SUFFICIENT TO SUPPORT FULL FUEL TANK WEIGHT (APPROX 595 LBS) EXPOSED STUD LENGTH 1.00-1.25 (12) REQUIRED.

B	DIM 38.73-38.75 WAS 38.75.	09 FEB 2015	LT-DG	JD		72N0223P15
A	INITIAL RELEASE OF -01 & -02.	28 MAR 14	LT-DG	JD		72N0230P14
SYM	REVISION RECORD	DATE	BY	ENGR.	M.E.	NPCA NO.

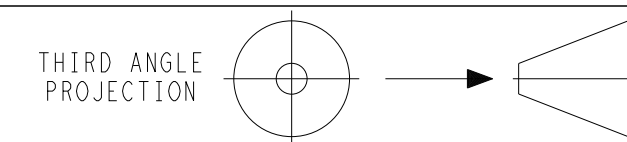

IMPERIAL INCH FORMAT:
UNLESS OTHERWISE SPECIFIED
DIMENSIONS ARE IN INCHES WITH
METRIC CONVERSIONS IN [MILLIMETERS]

TITLE
INSTL INSTR
SOLARA NDH APX

DRAWING NO.	REV
98-03335	B
SHEET 3 OF	

SUPERSEDES

PRINT DISTRIBUTION

EXPORT CLASSIFICATION:

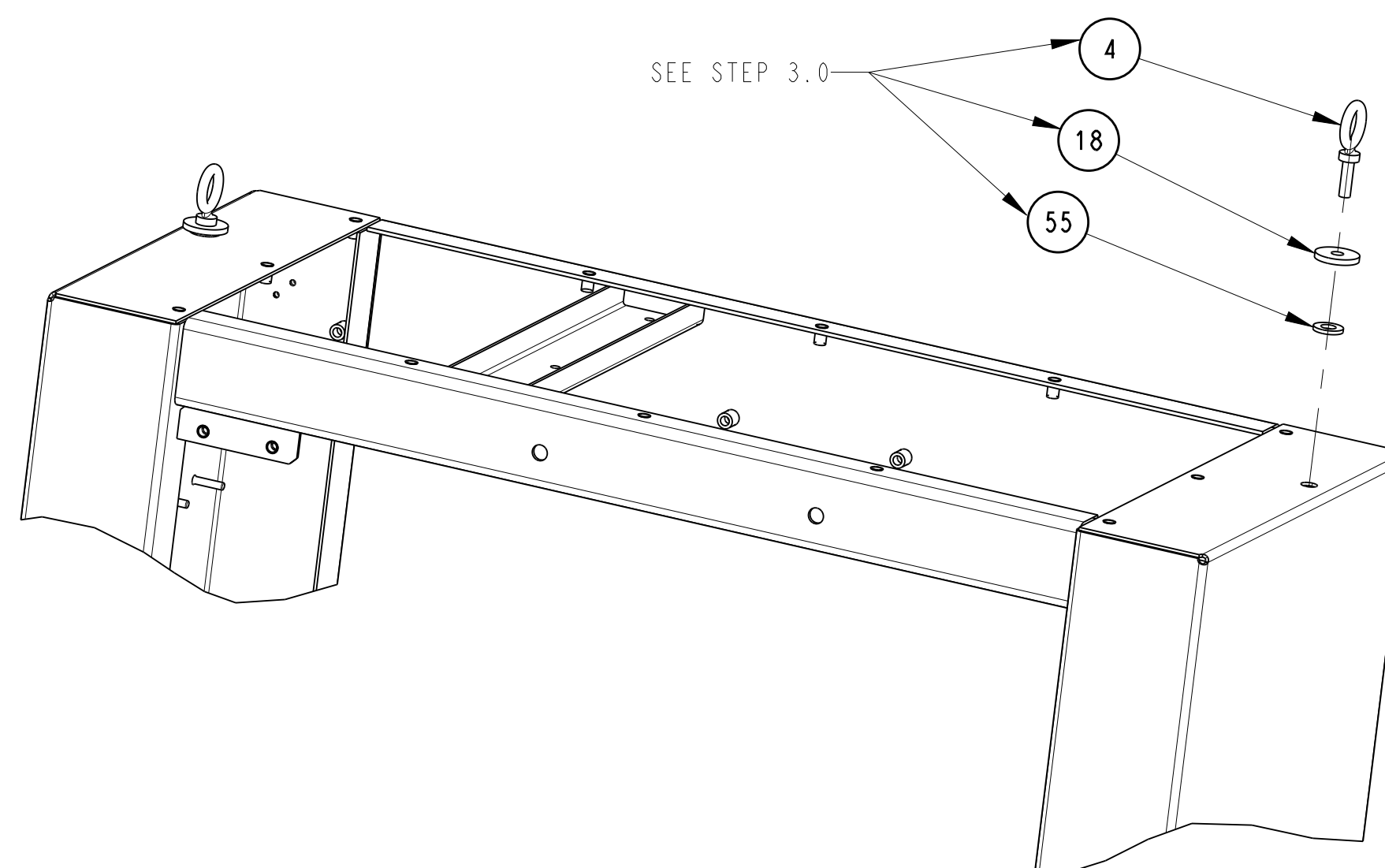
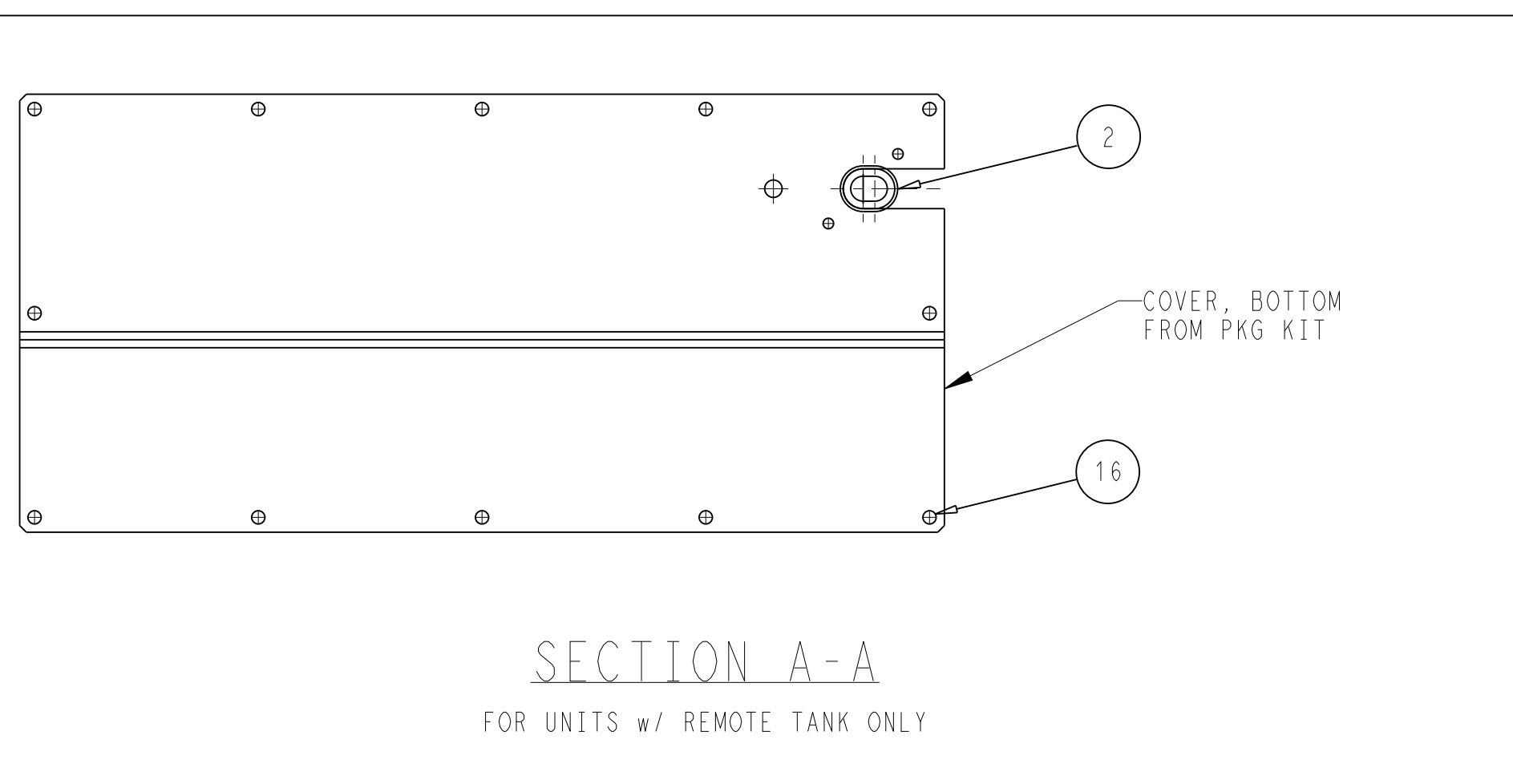

PREPARE UNIT FOR INSTALLATION:

- 1.0 PREPARE THE BODY TO RECEIVE THE UNIT. DIMENSIONS FOR EVAPORATOR OPENING AND MOUNTING STUD LOCATIONS ARE ON SHEET 3 OF THIS DRAWING.
- 2.0 INSTALL BATTERY ACCORDING TO INSTRUCTIONS ON SHEET 5.
- 3.0 PREPARE THE UNIT FOR LIFTING: LOCATE THE 2 EYEBOLTS (ITEM 4), 2 HARD WASHERS (ITEM 18) & 2 SOFT WASHERS (ITEM 55). ASSEMBLE AS SHOWN PLACING THE SOFT WASHER AGAINST THE UNIT. FINGER TIGHTEN UNTIL THE EYEBOLT AND 2 WASHERS ARE TIGHT AGAINST THE UNIT. TIGHTEN EACH EYEBOLT AN ADDITIONAL HALF TURN.

WARNING: MAKE CERTAIN EACH EYEBOLT & TWO WASHERS ON EACH SIDE OF THE UNIT HAVE BEEN SECURELY ASSEMBLED TO THE UNIT BEFORE PROCEEDING. DOUBLE CHECK THAT EACH HAS BEEN TIGHTENED PER THE INSTRUCTIONS ABOVE.

- 4.0 USING LOCKING HOOKS OR CLEAVISES, HOOK THE LIFTING APPARATUS (LIFTING SPREADER BAR WITH SUFFICIENT CAPACITY TO SUPPORT THE UNIT AND BATTERY (IF INSTALLED)) THROUGH THE LIFTING EYEBOLTS. BEFORE STARTING TO LIFT THE UNIT, ENSURE THAT THE APPARATUS IS LOADING EACH UNIT LIFTING POINT VERTICALLY WITHOUT ANY ANGLE.

UNIT INSTALLATION:

- 5.0 RAISE THE UNIT AND INSTALL IN THE BODY OPENING. ENSURE THAT ALL FOUR STUDS ARE FULLY ENGAGED IN THE UNIT FRAME. PLACE WASHER (ITEM 14) AND LOCK-NUT (ITEM 8) ON EACH OF THE 4 STUDS. SNUG THE NUTS, THEN EVENLY TIGHTEN ALL FOUR TO 60 FT-LB/18.6 NM USING A TORQUE WRENCH. REMOVE LIFTING APPARATUS, EYEBOLTS & WASHERS.
- 6.0 INSTALL BOTTOM COVER USING ITEM 16.
- 7.0 ROUTE FUEL AND COOLANT OVERFLOW LINES THRU BOTTOM OPENING OF UNIT.
- 8.0 INSTRUCTIONS FOR FUEL LINE CONNECTION ARE SUPPLIED WITH THE FUEL TANK KIT.
- 9.0 ROUTE DISPLAY CONTROL HARNESS AS SHOWN ON SHEET 4 AND AFFIX USING ITEMS 6 AND ITEM 20.
- 10.0 ASSEMBLE DISPLAY MODULE TO DISPLAY MODULE BRACKET PER INSTRUCTIONS ON SHEET 5. PLUG CONTROL WIRE INTO BACK OF DISPLAY MODULE. AFFIX DISPLAY MODULE ASSEMBLY WITH ITEM 6 AS SHOWN ON SHEET 4.

WARNING: DISPLAY MODULE ASSEMBLY SHOULD NOT BE CONNECTED UNTIL BATTERY INSTALLATION IS COMPLETE. THIS SEQUENCE WILL PREVENT THE POSSIBILITY OF THE UNIT FROM INADVERTENTLY STARTING DURING THE BATTERY INSTALLATION PROCESS

AFTER INSTALLATION:

- 11.0 PERFORM PRE-DELIVERY INSPECTION. COPIES OF COMPLETED CHECKLIST SHOULD BE SUPPLIED TO SELLING DEALER AND CUSTOMER.
- 12.0 OPERATE UNIT FOR A MINIMUM OF 8 HOURS THEN PERFORM FINAL INSPECTION ON UNIT.
- 13.0 IMPORTANT: PRIOR TO FINAL DELIVERY TO CUSTOMER, WARRANTY REGISTRATION MUST BE COMPLETED. ONE COPY SHOULD BE PROVIDED TO THE CUSTOMER, ONE COPY TO THE SELLER, AND THE FINAL COPY MUST BE SENT TO CARRIER TRANSCOLD. IN-SERVICE DATE MUST BE STAMPED ON THE UNIT IN THE PROPER LOCATION (SERIAL NUMBER PLATE) TO ACTIVATE WARRANTY COVERAGE.
- 14.0 INSTRUCTIONS FOR FUEL LINE CONNECTIONS CAN BE FOUND ON APPROPRIATE INSTALL DRAWING LISTED IN "CROSS REFERENCE INDEX" CHART, SHT. 1. INSTRUCTIONS ARE SUPPLIED WITH EACH FUEL TANK KIT.
- 15.0 ITEMS 58, 72, 76, 78 ARE FOR CONNECTING THE SUPPLY LINE. ITEMS 60, 70 ARE FOR CONNECTING THE RETURN LINE. ITEM 56 QTY. 2 ARE USED ON INLET AND OUTLET OF THE FUEL PUMP.

UNIT REMOVAL:

- 16.0 FOLLOW THE SAME PROCEDURES IN STEPS 3.0, WARNING BOX & 4.0 BEFORE REMOVING UNIT.

SCALE 0.200

VIEW SHOWN WITHOUT SKINS

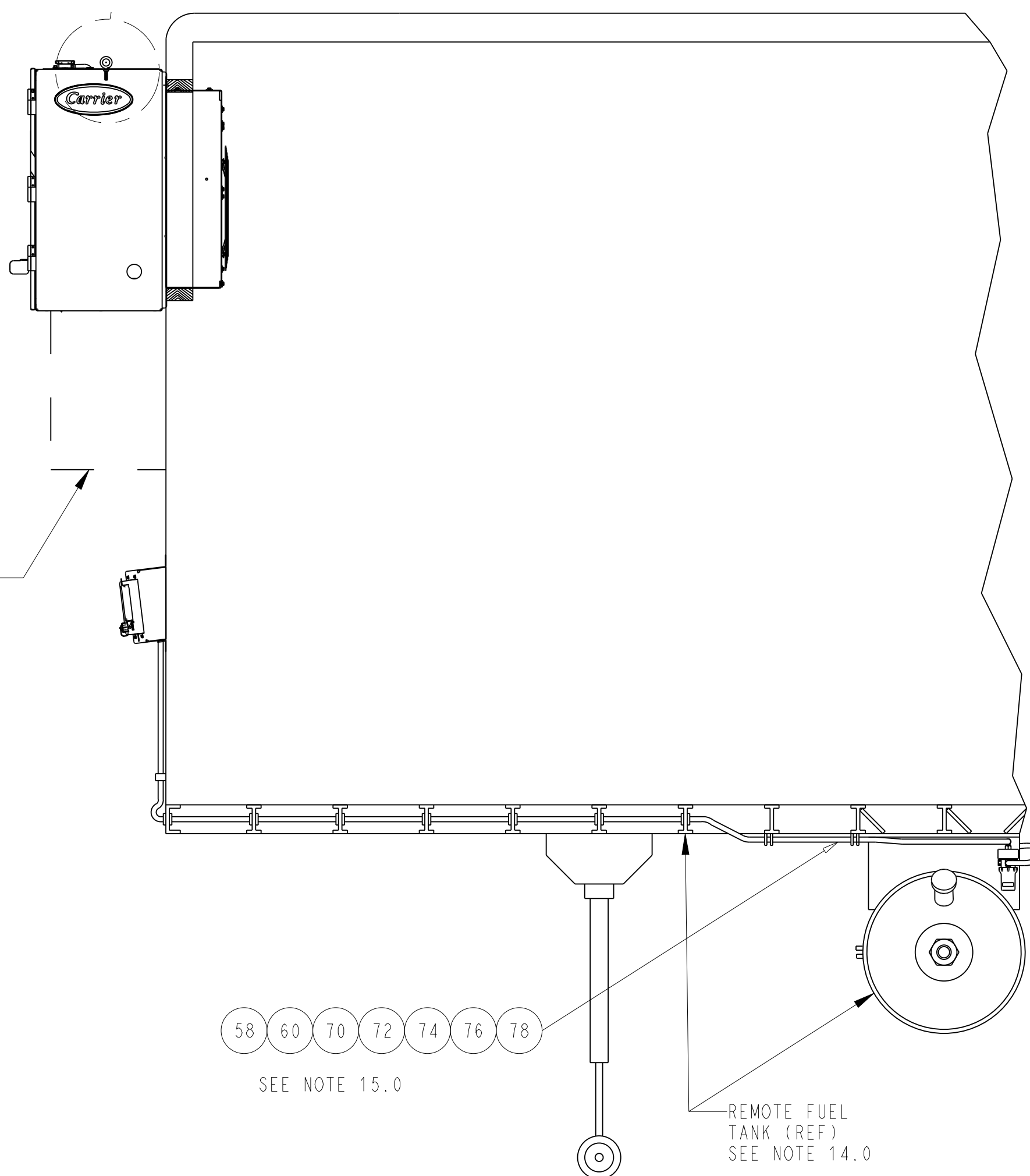
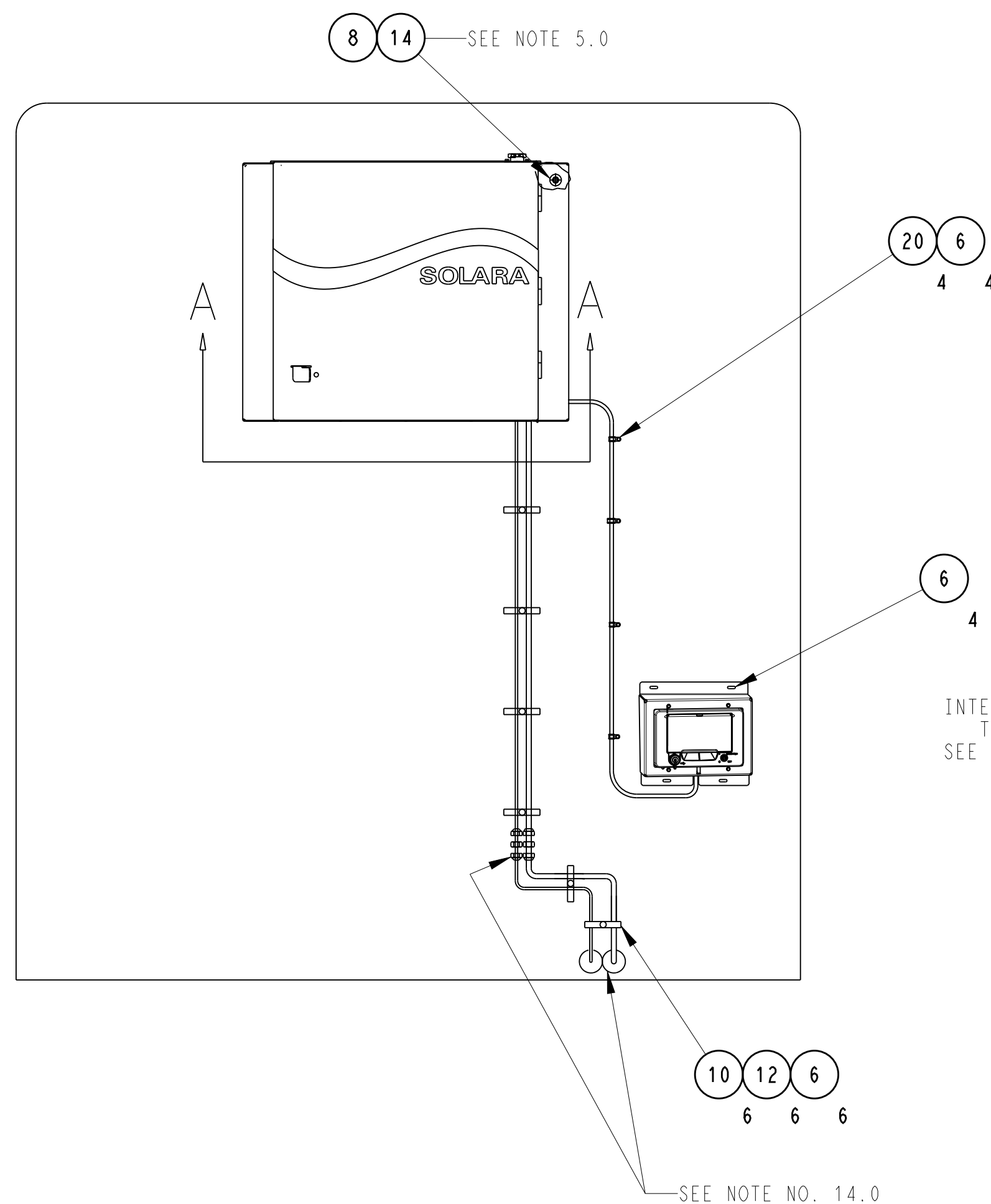

UNIT INSTALLATION

B	UNIT INSTALLATION NOTE: ADDED 9.0 & 10.0; ADDED WARNING NOTE TO 10.0. UNIT REMOVAL NOTE 16.0 WAS 9.0. RENUMBERED 11.0 THRU 15.0 WAS 10.0 THRU 14.0.	09 FEB 2015	LT-DG	JD		72N0223P15
A	INITIAL RELEASE OF -01 & -02.	28 MAR 14	LT-DG	JD		72N0230P14
SYM	REVISION RECORD	DATE	BY	ENGR.	M.E.	NPCA NO.

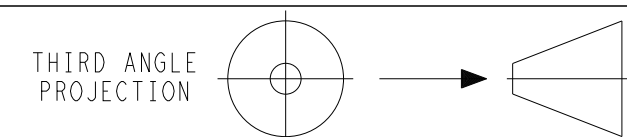

IMPERIAL INCH FORMAT: UNLESS OTHERWISE SPECIFIED DIMENSIONS ARE IN INCHES WITH METRIC CONVERSIONS IN [MILLIMETERS]

TITLE

INSTL INSTR
SOLARA NDH APX

DRAWING NO.

98-03335
SHEET 4 OF

REV
B

BATTERY INSTALLATION

PARTS REQUIRED FOR INSTALLATION OF BATTERY ARE LOCATED IN A POLY BAG ATTACHED TO THE BATTERY TRAY. LOCATE THIS BAG, REMOVE PARTS AND BAG FROM THE UNIT.

- 1.0 CUT THE TIE-WRAPPS THAT ARE SECURING THE BATTERY CABLES. MAKE CERTAIN NOT TO ACCIDENTALLY CUT THE BATTERY CABLES.
- 2.0 PLACE EACH J-HOOK IN THE SIDES OF THE BATTERY TRAY MAKING CERTAIN THE HOOK IS ORIENTED AWAY FROM THE BATTERY AS SHOWN.
- 3.0 LOOSEN THE FRONT BATTERY BRACKET TO EASE ASSEMBLY. DO NOT REMOVE BRACKET.
- 4.0 PLACE BATTERY IN TRAY WITH NEGATIVE (-) TERMINAL TOWARD THE FRONT OF THE UNIT.
- 5.0 INSTALL THE BATTERY HOLD DOWN, WASHERS AND LOCK NUTS AS SHOWN. EVENLY TORQUE EACH NUT TO 25 IN-LBS (2.8 Nm) TO PREVENT BATTERY MOVEMENT. DO NOT OVER-TIGHTEN.
- 6.0 ROUTE THE BATTERY CABLE TOWARDS THE FRONT OF THE UNIT. CONNECT THE RED BATTERY CABLE TO THE POSITIVE(+) BATTERY TERMINAL.
- 7.0 CONNECT THE BLACK BATTERY CABLE TO THE NEGATIVE(-) BATTERY TERMINAL (USE OF CORROSION INHIBITOR IS RECOMMENDED). MAKE CERTAIN WIRES ARE NOT RUBBING ANY OBJECT. TIGHTEN AS REQUIRED TO PROVIDE PROPER CONNECTION.

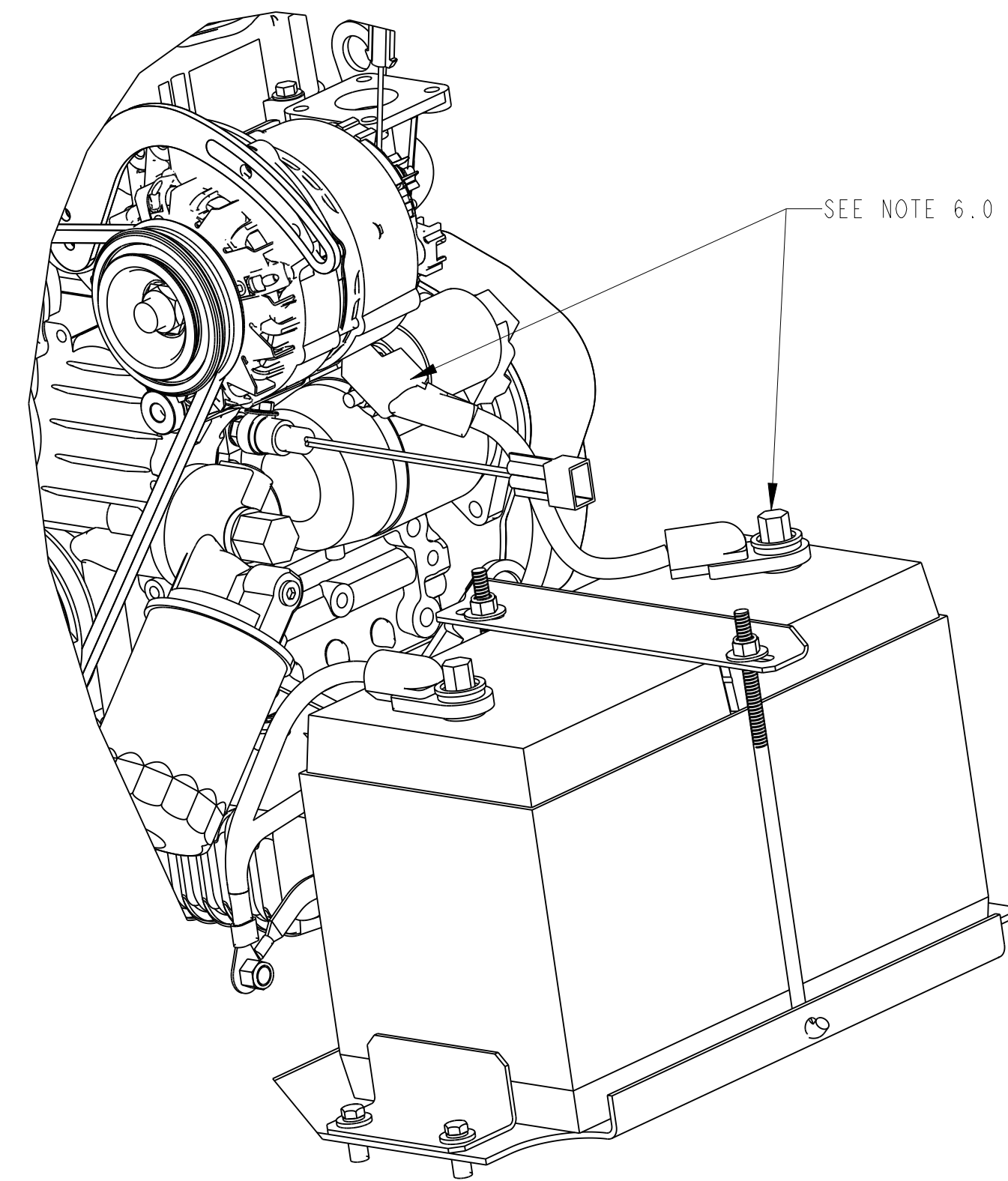
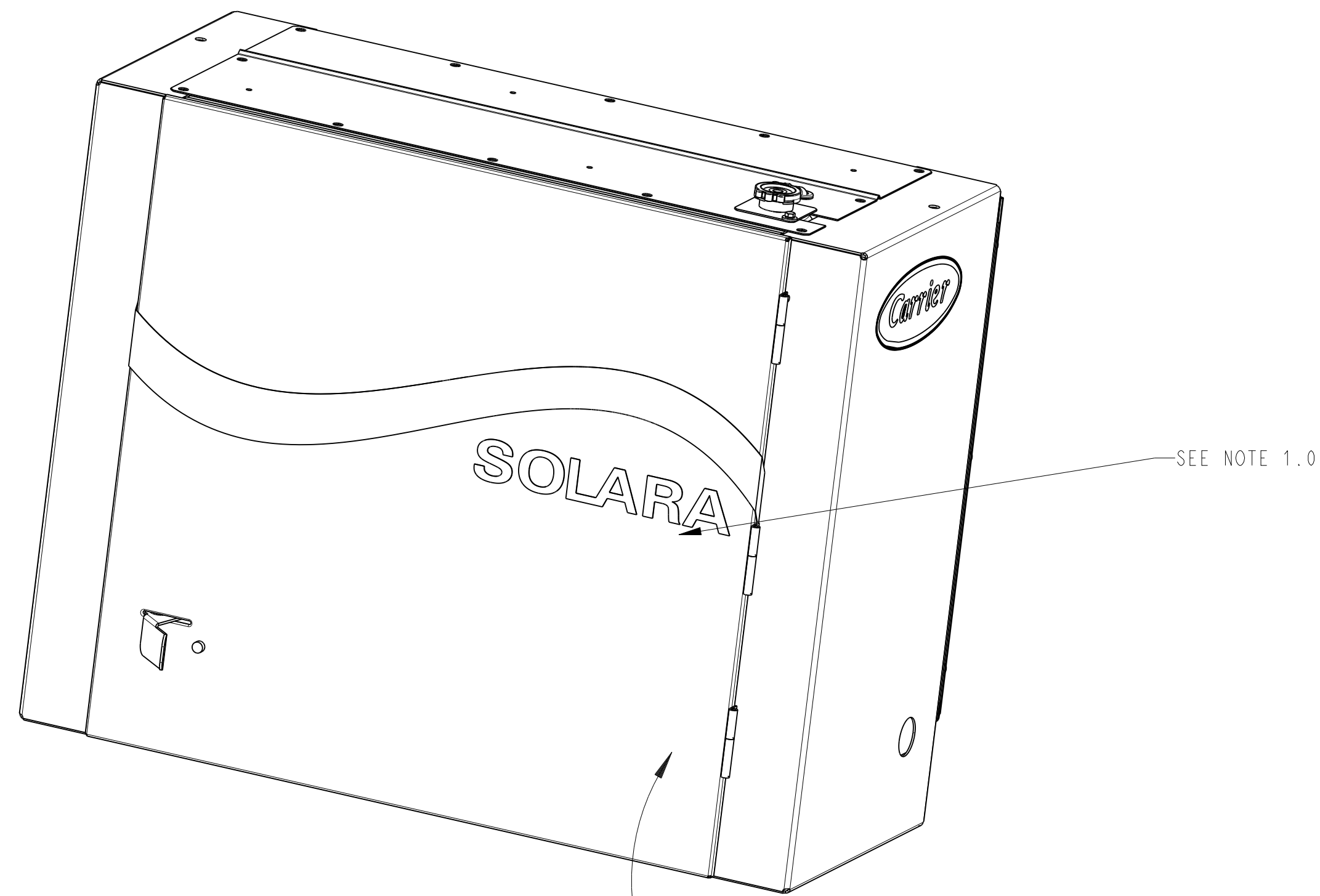

© BATTERY CABLE INSTALLATION

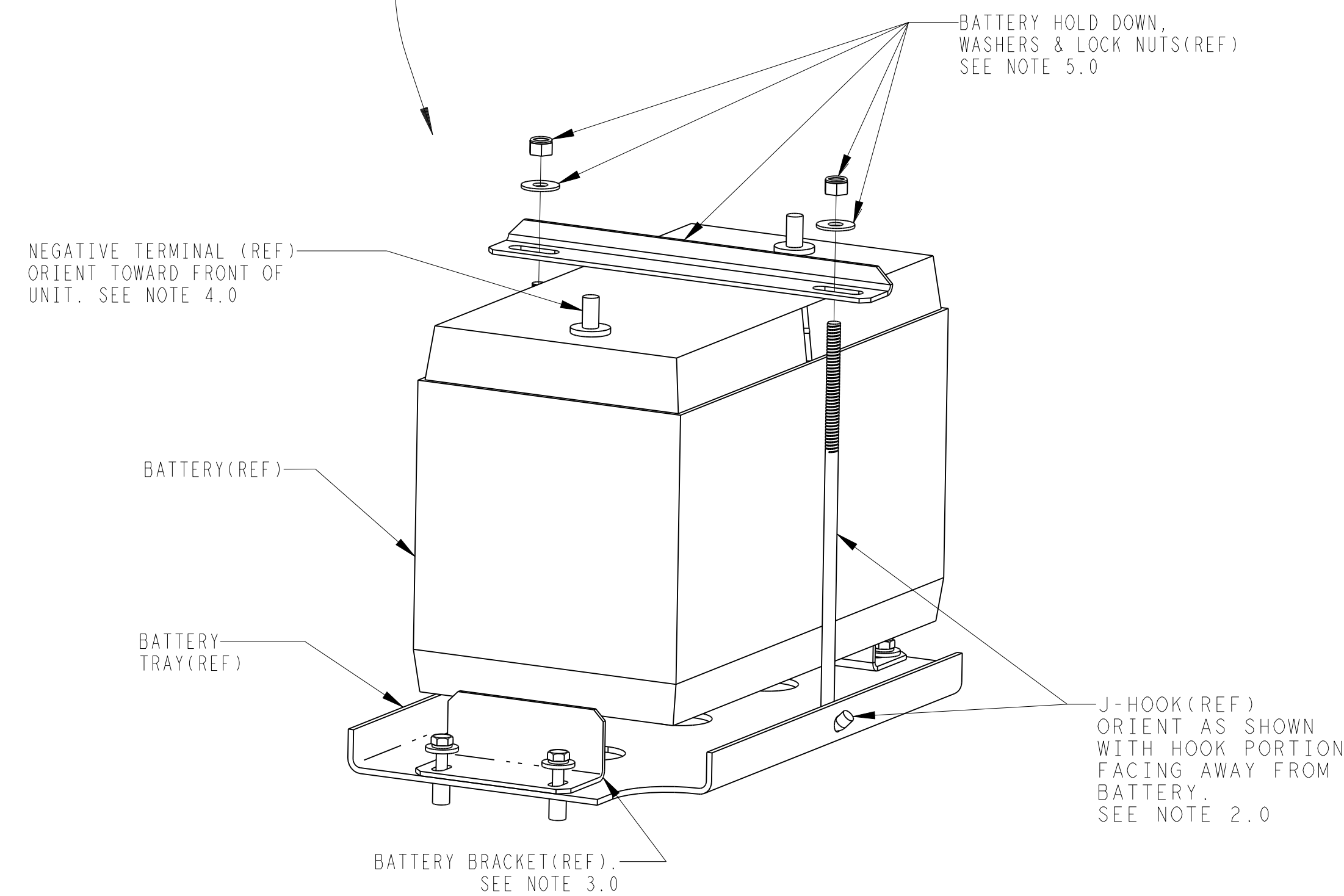

BATTERY INSTALLATION

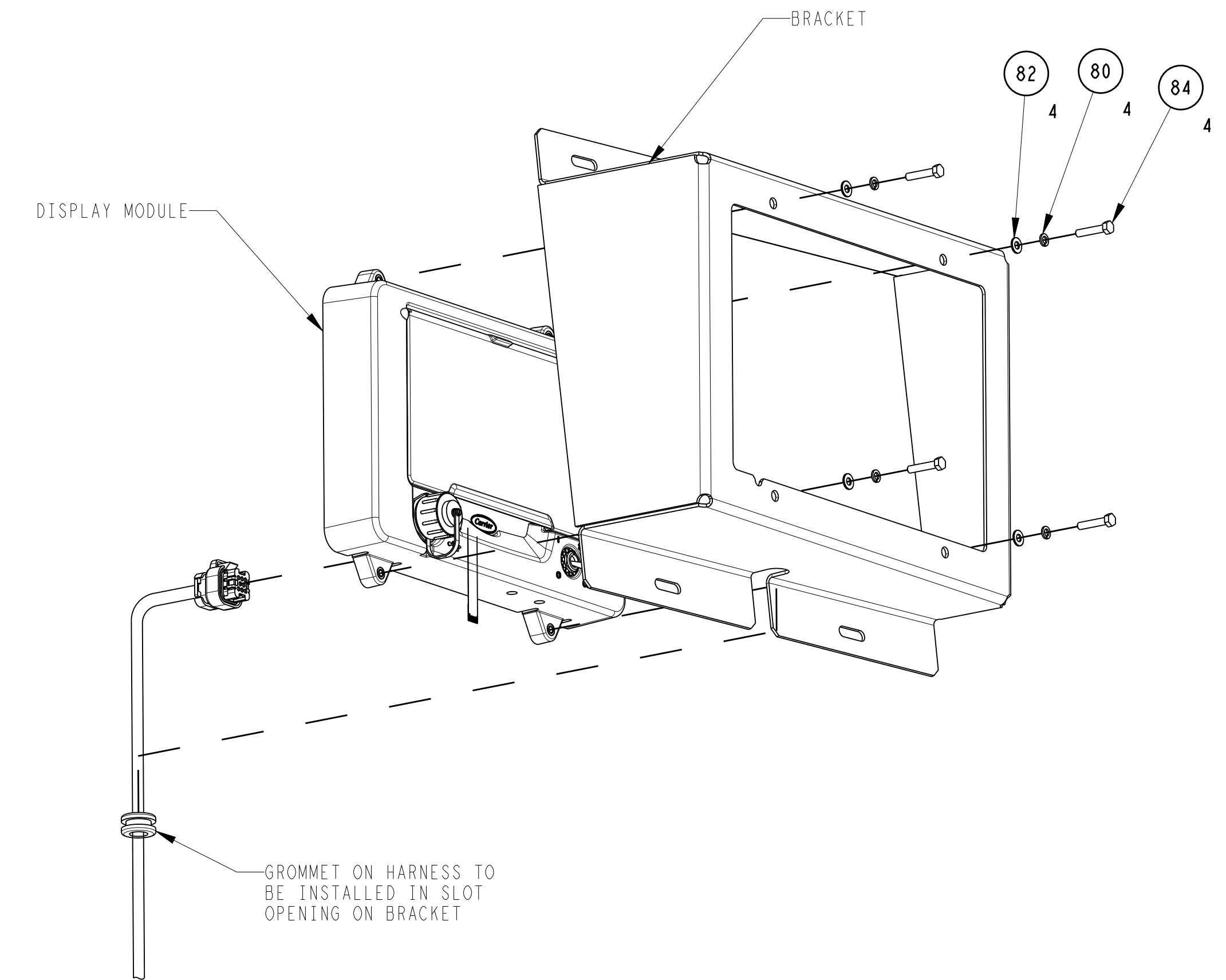

DISPLAY MODULE AND BRACKET ASSEMBLY
 SEE NOTE 10.0

C	ADDED "BATTERY CABLE INSTALLATION" VIEW. UPDATED NOTE 6.0 AND ADDED NOTE 7.0.	20 JUL 2015	LT-DG	JD		72N0295P15
B	ADDED NOTE "SEE NOTE..." TO DISPLAY MODULE ASSY.	09 FEB 2015	LT-DG	JD		72N0223P15
A	INITIAL RELEASE OF -01 & -02.	28 MAR 14	LT-DG	JD		72N0230P14
SYM	REVISION RECORD	DATE	BY	ENGR.	M.E.	NPCA NO.

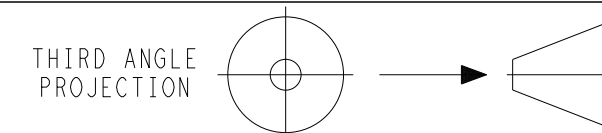

IMPERIAL INCH FORMAT:
 UNLESS OTHERWISE SPECIFIED
 DIMENSIONS ARE IN INCHES WITH
 METRIC CONVERSIONS IN (MILLIMETERS)

TITLE

INSTL INSTR
 SOLARA NDH APX

DRAWING NO.

98-03335
 SHEET 5 OF

REV

C